

**DESCRIPTION:**

The GT-1A is an audio only tenant station for the GT series Multi-Unit entry system. It is equipped with a Talk, Door Release, and optional Service Button.

When a visitor calls, the tenant station rings and is answered by one touch of the Talk button. The GT-1A also has the capability of calling the Concierge/Security Guard station(s), turning on a light while speaking with a visitor at the entrance, receiving an emergency tone from a pull cord or panic call button, and releasing a door.

The GT-1A is designed to be surface mounted, and has a slim streamlined design. Up to four GT-1A units can be used in the same tenant location.

Communication is hands-free at the entrance station when a tenant answers the call, and is either VOX hands-free or push-to-talk at the tenant station when speaking with the visitor.

**GT-1A FEATURES:**

- Hands free audio communication
- Door release to the door where communication is established
- Call to Security Guard / Concierge station
- Optional individual doorbell rings unique tone, notifying resident that someone is at their door
- Optional activation of outside light while talking to entrance station
- Optional connection of panic call station (GFK-PS), alerting with tone and call to Concierge
- Separate volume controls for call tone and communication
- Simply 2-conductor common bus wiring
- Surface mounts to a wall on 1-gang box or ring
- ABS plastic construction

# GT-1A

## Audio Only Tenant Station

### FEATURE CALL-OUT:

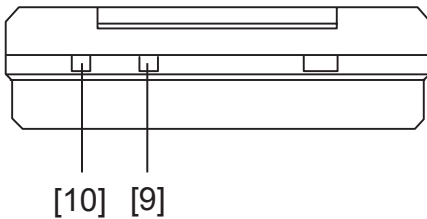
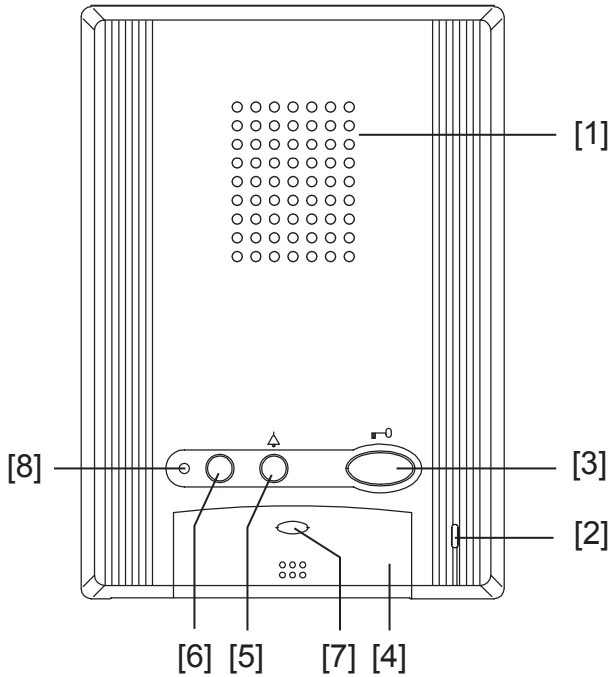

### FEATURE CALL-OUT DEFINITIONS:

- [1] Speaker
- [2] Microphone
- [3] Door release button
- [4] Talk button
- [5] Light button / Security guard station call button
- [6] Service button (option)
- [7] Talk LED
- [8] Call tone off LED
- [9] Receive volume control
- [10] Call tone volume control

### SPECIFICATIONS:

- Power Source: 24V DC, supplied from GT-BC
- Call: Varying ring tones from entrance panel, concierge, or doorbell
- Communication: Hands-free or Press-to-talk
- Capacity: Max. 4 tenant stations per resident location
- Wiring: 2-conductor, PE insulated, common bus
- Mounting: Wall mount
- Temperature: 32-104°F (0-40°C)
- Dimensions: 6-7/8" H x 4-15/16" W x 1-1/4" D
- Weight: Approx. 0.70 lbs (330g)

