

CLIPSAL[®]

by Schneider Electric

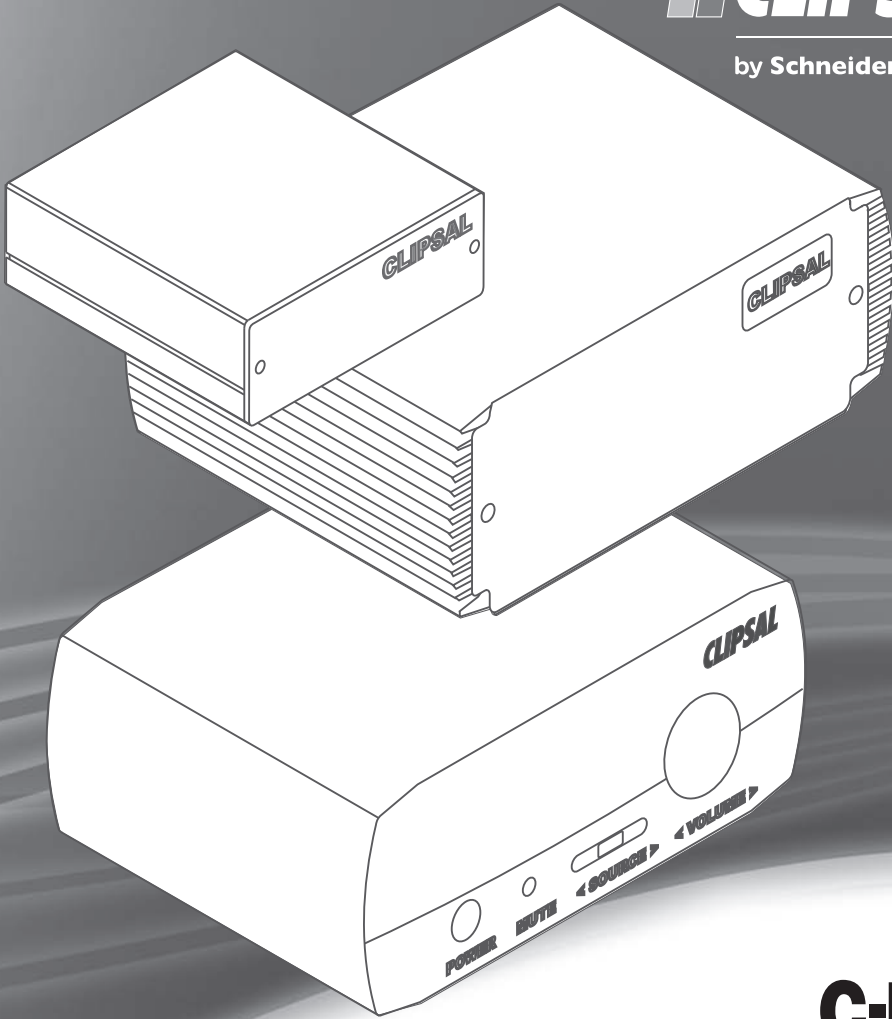

C-Bus[®]

Multi Room Audio Amplifier

560125D/2

560125R/2

560110R

Installation Instructions



Contents

1	Introduction	3
1.1	Product Range	3
1.2	Safety and Product Handling	4
1.3	Additional Product Information	6
2	Installation	7
2.1	Installation Steps	7
2.2	Equipment Placement	8
2.3	Wiring Diagrams	9
3	Wiring Details	11
3.1	Speaker Connections	11
3.2	C-Bus Network Cabling	12
3.3	Stereo Input Connection	13
3.4	Digital Audio Cabling for Multiple Amplifiers	13
4	Power Supply Connection	14
5	Commissioning and Testing	15
6	Troubleshooting	15
7	Specifications	16
8	Standards Complied	18
9	Two-Year Warranty	19

The information in this manual is provided in good faith. Schneider Electric endeavours to ensure the relevance and accuracy of the information. However, it assumes no responsibility for any loss incurred as a result of its use. Schneider Electric does not warrant that the information is fit for any particular purpose, nor does it endorse its use in applications that are critical to the health or life of any human being. Schneider Electric reserves the right to update the information at any time without notice.

November 2009

1 Introduction

The installation instructions cover a 'standalone' Multi Room Audio (MRA) amplifier installation without a matrix switcher. A standalone amplifier configuration includes connections to a power supply, loudspeakers and a local stereo audio source. You can also connect additional MRA amplifiers using digital audio cables.

If you are installing a Multi Room Audio system that includes a matrix switcher, refer to the information found in the *C-Bus Multi Room Audio Matrix Switcher and System Installation Instructions*.

After you install the amplifier, as described in this document, refer to the *C-Bus Multi Room Audio Amplifier User's Guide* for operating instructions.

1.1 Product Range

Three types of MRA amplifiers are available as shown in Table 1.

Catalogue Number	Description
560125D/2	MRA Desktop Amplifier
560125R/2	MRA Remote Amplifier
560110R	MRA Low Power Remote Amplifier
560110E	Enclosure only

Table 1. Amplifier catalogue numbers

Amplifiers

The **560125D/2 Desktop Amplifier** is a high-power unit that has front panel controls and remote sensor window, in addition to the C-Bus network interface. The desktop amplifier is usually placed on a bedside table or on a shelf for easy access.

The **560125R/2 Remote Amplifier** is a high-power unit that does not have front panel controls. The high power remote amplifier is normally placed in an equipment rack, built-in-robe, or above the ceiling. C-Bus input devices, such as wall switches, DLT switches, or a touchscreen provide volume and tone control.

The **560110R Low Power Remote Amplifier** has a compact form factor that allows up to 4 units to be installed in a row in a standard 19-inch equipment rack. Unused locations can be filled using the 56011E empty enclosure. C-Bus input unit provide volume and tone control.

Refer to the 'Controls and Indicators' in the *C-Bus Multi Room Audio Amplifier User's Guide* for more details.

Power Supplies

Each Multi Room Audio Amplifier in a standalone installation requires a power supply (See Table 2) connected to the amplifier's EXTERNAL POWER socket.

Catalogue Number	Description
5600P24/3750AU	Switch Mode Power Supply, 24 V d.c. @ 3.75 A. Suits the 560125D/2 Desktop and the 560125R/2 Remote Amplifiers.
5600P24H3750A	High Temperature Switch Mode Power Supply, 24 V d.c. @ 3.75 A. Required for all high temperature locations. See note.
5600P24/1250	Power Supply, 24 V d.c. @ 1.25 A. Suits the 560110E Low Power Amplifier.

Table 2. Power supplies for the amplifiers

Note: When the power supply is installed in warm to hot locations, you must use the High Temperature Switch Mode supply for all amplifier types. The 3.75A High Temperature Power Supply includes a cable adapter for the 560110R Low Power Amplifier.

1.2 Safety and Product Handling

Read and understand the following safety hazard information.

WARNINGS

Failure to observe these warnings could lead to electrical shock and serious injury:

- Use only the specified power supply unit that is of the correct type for the amplifier you are using. Do not substitute any other power supply.
- Replace the power supply unit if the power supply or the cord is damaged. The power supplies cannot be repaired and there are no user serviceable parts inside.
- Do not allow liquids to splash or drip on the power unit or the amplifier. Do not place an object containing liquid, such as a vase, on top of the equipment.

To prevent overheating and the possibility of a fire, always provide adequate ventilation around the power supply. Do not cover the power supply or enclose it in a box.

Prevent tripping and falling by installing equipment in safe locations where cables do not create a tripping and falling hazard.

The amplifiers can produce sounds loud enough to cause permanent hearing loss. Prevent hearing loss by doing the following:

- Mute the speakers before connecting an audio source.

- Turn down the volume setting before connecting headphones. Connect the headphones to the amplifier BEFORE placing them on your head.
- Do not allow children to use the Multi Room Audio equipment without adequate supervision.

Cautions

Prevent damage to the equipment and extend its useful life by following these guidelines:

- Only use a Clipsal approved power supply to power an amplifier. Using any other power supply can damage the unit, and void the warranty.
- The amplifiers are designed for indoor use only in moderate to tropical climates. Operating the equipment at high temperatures for extended periods will reduce reliability and product life.
- Provide adequate ventilation. Ensure at least 50 mm of free space is available at each side of the high power amplifiers. Allow at least 15 mm of free space directly above the units.
- Never insert C-Bus RJ45 plugs into LAN or Digital Audio sockets. Damage to the equipment can occur. The use of colour-coded network cables is highly recommended.
- Disconnect power from the amplifier before connecting or disconnecting cables.

Care Instructions

Maintain the appearance of the equipment by following these guidelines:

- Use a soft lint free cloth for cleaning.
- Do not use chemicals or spray cleaners.
- Do not use hard, sharp objects to select the controls.
- Do not allow dust to accumulate on the equipment.

1.3 Additional Product Information

If you have technical questions about the installation of the Multi Room Audio equipment, contact your nearest Clipsal Integrated Systems or Schneider Electric customer care centre. The contact information is on the back cover of this document.

Related Documents

The *C-Bus Multi Room Audio Amplifier User's Guide* contains instructions for using the amplifiers in a standalone installation.

The *C-Bus Multi Room Audio Matrix Switcher and System Installation Instructions* is a system-level document that provides details about optional features of the amplifiers that are not discussed in this document.

The *C-Bus Multi Room Audio Matrix Switcher and System User's Guide* provides description of amplifier use at the system level.

C-Bus wall switch and touchscreen installation instructions and user's guides (various models). The instructions provided with the Saturn and Neo wall switches tell you how to set up the C-Bus input units.

Online Product Information and Downloads

At the Clipsal Integrated Systems (CIS) Portal you can access software downloads and literature. Visit the following Internet location:

<http://www.clipsal.com/cis/portal> Select the 'Technical' area.

Software Help Files

When using *C-Bus Toolkit™* configuration software and other Clipsal software products, be sure to access the Help files for technical questions.

2 Installation

This document covers the standalone audio amplifier installation without a matrix switcher. Installing multiple amplifiers is discussed in this document. If you need additional details about the amplifier's features or connections, refer to the MRA system-level documents listed previously.

2.1 Installation Steps

The following table gives you an overview of the installation process flow.

Step	Description
Read safety information	Make sure you understand the critical safety and product handling information and gather product documentation before you start. Sections 1.2, 1.3, 1.4.
Plan the installation	Select a convenient location for the amplifier and the speakers. Determine which C-Bus input units will control the amplifier. Locate a wall power outlet for the power supply. Consider the placement and connection of audio source equipment. Section 2.2.
Configure with software tools	Use Toolkit to modify the C-Bus network configuration to add the amplifier and set up its relationship with C-Bus input units. If you are using a C-Touch touchscreen, use Piced software to set up the interface.
Pre-wire	Install the C-Bus network, speakers and audio source cabling. If you are connecting two or more amplifiers, install Digital Audio cables as well.
Install the physical units	Install the amplifier, speakers and power supply. Then connect the required cables.
Apply power	Check all wiring and plug the power supply in to the wall power outlet.

Table 3. Installation steps

2.2 Equipment Placement

When installing the amplifier and its speakers, you should choose a location that is close to the audio input source and a wall power outlet for the amplifier. Doing so will minimise cabling issues. Proximity to the C-Bus input units that control the amplifier should be considered as well.

You should consider the following factors when choosing a location for the amplifier and speakers. Be sure that:

- there is a power outlet for each amplifier's power supply.
- the amplifier is not in direct sunlight or near a source of heat.
- cable runs are as short as possible.
- cables and speaker wires do not present a tripping hazard.
- outdoor speakers are securely fastened using stainless steel hardware.

For multiple-amplifier installations you should make the decision whether to set up the amplifiers in a centralised layout or a distributed layout.

A **Centralised** layout is appropriate when using multiple 560110R Low Power Amplifiers. This is especially true if the amplifiers are installed in a 19-inch equipment rack. In a centralised layout the networking and digital audio cable runs will be shorter and the speaker wire runs will be longer. Also, multiple power outlets are needed at one location.

A **Distributed** layout allows you to install amplifiers in convenient locations in the home. For example, you might want to install a remote amplifier in a space above a ceiling and use concealed speakers in the ceiling. A distributed layout keeps the speaker wire runs shorter.

2.3 Wiring Diagrams

Wiring diagrams are provided for typical installations using one amplifier (Figure 1) and more than one amplifier (Figure 2). Note that multiple amplifiers have one analogue input source and a digital audio connection between the amplifiers.

When making wiring connections, it is important to follow these guidelines:

- Do not plug a C-Bus network cable into a Digital Audio socket. You could damage the amplifier.
- Consistent speaker wiring polarity is important for good sound quality. If you use multiple speakers with an amplifier, follow the speaker manufacturer's recommendations.
- Speaker placement is important. You might have to move speakers to get the best results.
- Keep cable runs as short as possible.
- Use high quality cables of the proper type for the intended purpose. Refer to the information in the following subsections.

The wiring diagram in Figure 1 shows the connections for one amplifier with a single pair of speakers.

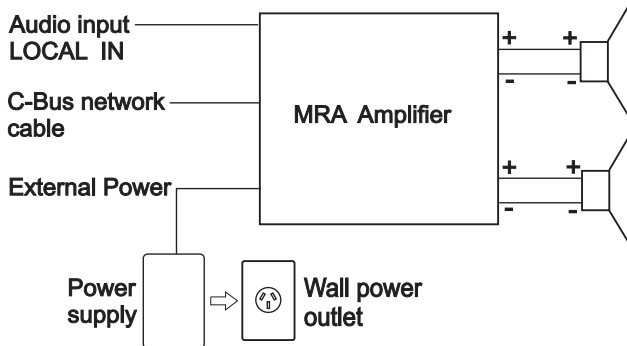

Figure 1. Single amplifier standalone installation diagram

In multiple amplifier installations, the amplifiers share a single audio source. The volume and tone settings for each amplifier can be independently controlled.

An RJ45 Tee connector, Catalogue Number 5600TEE, is needed to connect the Digital Audio signals between multiple 560110R Low Power Remote Amplifiers.

Do not make any electrical connections between the speakers on any two amplifiers or connect any speaker wiring to earth (ground). Poor sound quality will result.

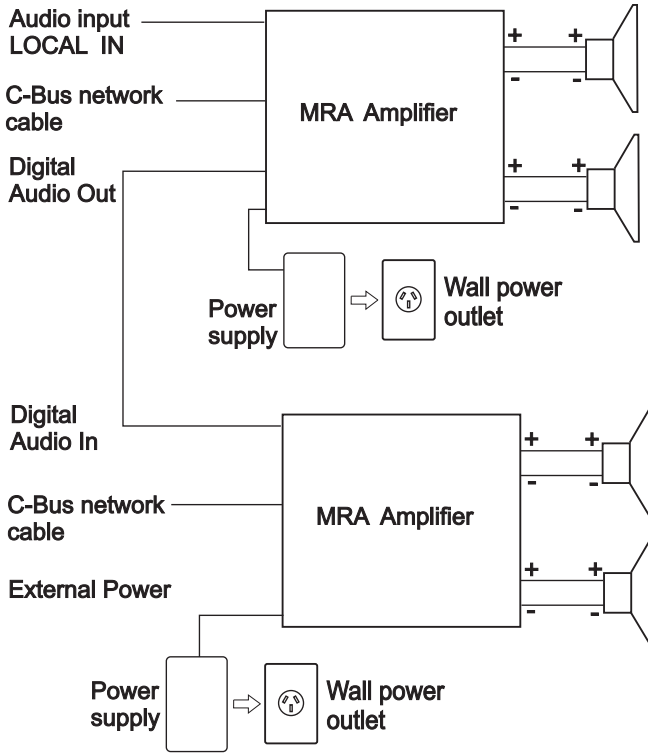

Figure 2. Two amplifiers connected to a single audio source.

Note for Figure 2. You can continue to connect Digital Audio cables to additional amplifiers. The analogue input, LOCAL IN, is connected to the first amplifier.

Clipsal offers the following cable and connectors:

Catalogue Number	Description
5005C305B (solid) 5005C305BST (stranded)	C-Bus network cable, Cat.5e, 4 pair, UTP cable, colour: Pink
RJ88P	Modular plug, 8 way, Category 5e
2SPK2C105	Speaker cable, 105 strands, equiv to 1.5 mm ²
2SPK2C259	Speaker cable, 259 strands, equiv to 3.0 mm ²

Table 4. Cables and connectors

3 Wiring Details

Use high quality cables and connectors for best results. Make sure that all connections are tight and that no strands of wire are protruding from the connectors. Bootlace crimps are recommended for twisted network cable connections.

3.1 Speaker Connections

The high power MRA amplifiers use spring-type connectors. The Low Power Remote Amplifier uses a screw-type connector.

Use low-impedance, stranded speaker cable to connect the loudspeakers to the output terminals on the amplifier. The impedance of the cables should not exceed 5% of the impedance of the speakers. As a general rule, the larger the diameter of the speaker cable's conductors, the lower the impedance.

Cautions

Avoid damage to the equipment by observing these cautions.

- Do not allow the positive and negative speaker wires to short together.
- Do not make any connection between speakers connected to different amplifiers.
- Do not connect any speaker wires to earth (ground).

Observe the positive (+) and negative (-) markings on the amplifier and make sure that you consistently connect the cables to the speakers throughout the installation. If speaker wire polarity is wrong, sound quality will be poor due to out-of-phase sound from the various speakers.

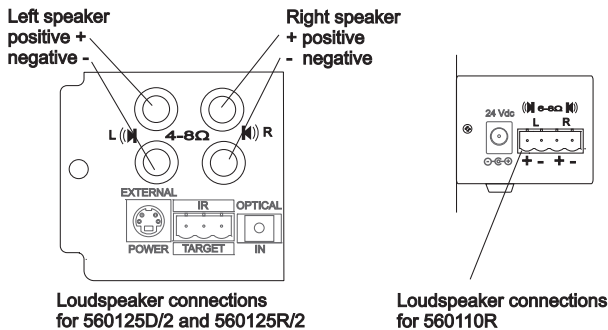

Figure 3. Amplifier loudspeaker terminals

In certain cases, you can connect multiple speakers to each channel of the amplifier by following the speaker manufacturer's recommendations.

3.2 C-Bus Connection

Each amplifier has a connection to the C-Bus network. C-Bus wall switches control the volume, bass and treble settings for the amplifier via the C-Bus network. C-Bus Toolkit configuration software is used to configure wall switches to control the amplifiers. Refer to the *C-Bus Multi Room Audio Amplifier User's Guide*, the wall switch documents, and C-Bus Toolkit Help.

The C-Bus network cables for the 560125D/2 and 560125R/2 high power amplifiers use RJ45 plugs. The C-Bus network cable for the 560110R Low Power Remote Amplifier is terminated with a screw-type connector. Figure 4 shows the C-Bus network cable wire assignments for both connector types.

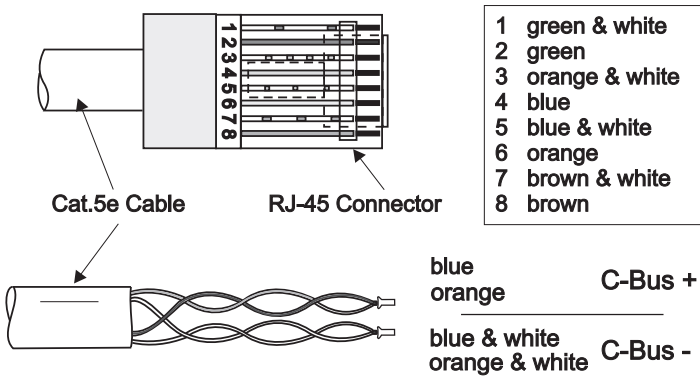

Figure 4. C-Bus network cable termination

Figure 5 shows the rear panel connection points for the C-Bus network cables.

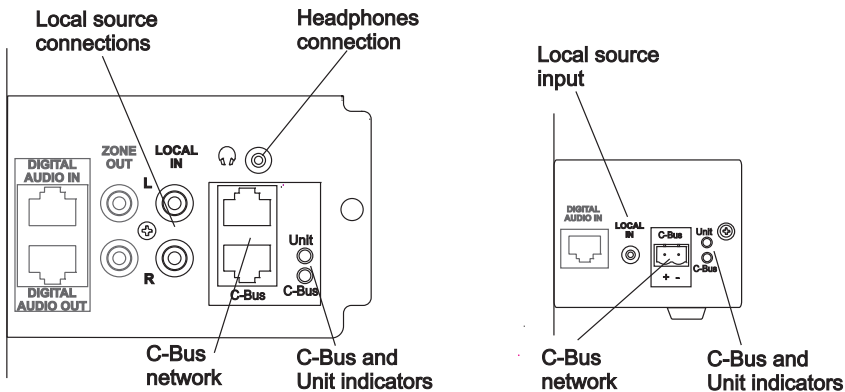

Figure 5. C-Bus network connectors on the back panels

3.3 Stereo Input Connection

The rear panel connectors for the local audio input are labelled LOCAL IN. See Figure 5. The high power amplifiers use RCA sockets and the low power amplifier uses a 3.5 mm stereo socket. The LOCAL IN is for connection to line level signals, normally labelled Audio Output on source devices.

Do not connect high-level speaker outputs from audio source equipment to the LOCAL IN inputs on the MRA amplifier. These high level signals will overdrive the input of the MRA amplifier and produce poor sound quality. Connect line level signal sources only.

Optical Input (optional)

If you have a standalone high power remote amplifier, you cannot use the OPTICAL IN and the LOCAL IN at the same time. If you wish to connect an optical source, disconnect the LOCAL IN cables.

If you have a standalone desktop amplifier, you can connect both an OPTICAL IN source and a LOCAL IN source. The Source switch allows you to toggle between these sources. However, you cannot use the OPTICAL IN and the DIGITAL AUDIO IN connections at the same time.

3.4 Digital Audio Cabling for Multiple Amplifiers

You can connect two or more MRA amplifiers together using the digital audio capabilities of the amplifiers. When connecting MRA amplifiers together, follow these guidelines and refer to Wiring Diagrams and Figure 5.

- Only one source input can be active for all connected amplifiers. Attaching multiple sources will cause poor audio quality.
- Each standalone MRA amplifier requires a power supply and speakers.
- Mark the digital audio cables so that they are not confused with C-Bus network cables. Never plug C-Bus network cables into digital audio or LAN sockets, or vice versa.
- If a 560110R Low Power Amplifier is connected to an upstream or a downstream amplifier, use an RJ45 Tee connector, Catalogue Number 5600TEE, at the digital audio socket.
- When using multiple amplifiers, be sure to wire the positive and negative speaker wires consistently to ensure the best sound quality. Also, you might have to experiment with speaker placement for left and right channels to get the best results.
- Install a ferrite filter on each digital audio cable.

4 Power Supply Connection

The 3.75 Amp-rated power supplies have a power cord and the 1.25 Amp-rated power supply is a plug-pack design. If you are using a High Temperature Power Supply with a 560110R Low Power Remote Amplifier, use the cable adapter that is provided with the power supply. Refer to the appropriate power supply instruction sheet.

1. Plug the end of the power supply output cable into the External Power connector on the back panel of the MRA amplifier. Refer to Figure 6.
2. Install the supplied ferrite filter on the power supply cable between the power supply and the MRA amplifier. The filter halves latch when closed over the cable.
3. After you have connected the C-Bus cable, loudspeakers and audio input, connect the power supply to a suitable wall power outlet. Refer to the appropriate sections in this document.

**External power connector for
560125D/2 and 560125R/2**

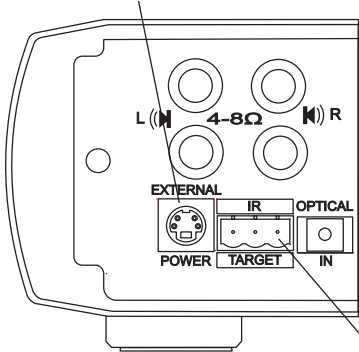

**External power
connector for
560110R amplifier**

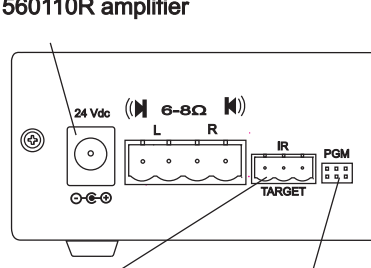

Infrared (IR) target
connector (See note)

Programming
(factory use only)

Figure 6. MRA Amplifier External Power connections

Note on Figure 6

The IR Target connectors on the amplifiers' rear panels are used to route IR control signals back to A/V equipment using the digital audio cables and IR emitters connected to the Matrix Switcher. Refer to the *C-Bus Matrix Switcher and System Installation Instructions* for more details.

The programming (PGM) connector is used at the factory to load firmware. The PGM connector is not used during installation or subsequent operation.

5 Commissioning and Testing

Follow these guidelines when testing the functionality of the installation.

- Configure the C-Bus wall switches to control the volume, bass/treble and muting before connecting an audio source. Refer to the wall switch instruction documents and to C-Bus Toolkit software Help.
- Be sure to power off amplifiers before connecting audio sources or network cables. Mute the speakers before connecting or disconnecting.
- Use an MP3 player or other equipment as an audio source.
- Do not Megger test the C-Bus network cable.
- Refer to the *C-Bus Multi Room Audio Amplifier User's Guide* for use of controls and C-Bus wall switches. Also refer to the wall switch documents.
- Refer to the *C-Bus Multi Room Audio Amplifiers User's Guide* for information about headphones and hand held remote control use.

6 Troubleshooting

Symptom	Possible Explanation
There is no sound after switching the Amplifier on (sound worked previously).	The volume may have been set to minimum, or the Amplifier may have been Muted (on a Desktop Amplifier) before the Amplifier was switched off.
The default volume, bass or treble settings have changed (when switching the Amplifier on).	If a power failure occurs when the Amplifier is on, the volume, bass and treble settings are saved and become the new defaults.
An Amplifier switches off, particularly when the volume is loud.	If insufficient current is available for the Amplifier, it will switch itself off. This may occur if the Amplifier receives its power from a Matrix Switcher.
Cannot hear any sound when using the optical input	Some digital audio formats (such as surround sound) are incompatible with the MRA system.

7 Specifications

560125D/2 Desktop and 560125R/2 Remote

Parameter	Description
Supply Voltage	24 V DC @ 3.75 A when using the external switch mode power supply 27 V d.c. when powered by the Matrix Switcher (via digital audio connection), refer to the system level documents
C-Bus supply voltage	15 to 36 V d.c.
C-Bus sink current	22 mA
Power consumption	90 W maximum
Maximum power output	28 W RMS into 4 Ω (0.514% THD)
Frequency response	40 Hz to 20 kHz (± 1 dB)
Total harmonic distortion (1 kHz, 20 W RMS into 4 Ω)	0.36% (using analogue input)
Signal to noise ratio	> 67 db (peak, unweighted)
C-Bus network clock and burden	Software selectable
Analogue input signal level (Local inputs)	2.8 V p-p maximum (47 k Ω)
D/A conversion	16 bit PCM
Operating temperature	Desktop Amp.: 10 to 40 °C (50 to 104 °F) Remote Amp.: 10 to 70 °C (50 to 158 °F)
Operating humidity	10 to 90% RH (non-condensing)
Dimensions (H x W x D)	74 mm x 180 mm x 215 mm, Desktop 71 mm x 175 mm x 212 mm, Remote

560110R Low Power Remote

Parameter	Description
Supply Voltage	27 V d.c. when powered by the Matrix Switcher (via digital audio connection), and/or 24 V DC @ 1.25A when using the external power supply or switch mode power supply
C-Bus supply voltage	15 to 36 V d.c.
C-Bus sink current	22 mA
Power consumption	30 W maximum
Maximum power output	10 W RMS into 4 Ω (0.514% THD)
Frequency response	40 Hz to 20 kHz (± 1 dB)
Total harmonic distortion (1 kHz, 20 W RMS into 4 Ω)	0.36% (using analogue input)
Signal to noise ratio	> 67 db (peak, unweighted)
C-Bus network clock and burden	Software selectable
Analogue input signal level (Local inputs)	2.8 V p-p maximum (47 k Ω)
D/A conversion	16 bit PCM
Operating temperature	10 to 70 °C (50 to 158 °F)
Operating humidity	10 to 90% RH (non-condensing)
Dimensions (H x W x D)	40 mm x 120 mm x 158 mm

8 Standards Complied

DECLARATIONS OF CONFORMITY

Australian/New Zealand EMC & Electrical Safety Frameworks and Standards



Regulation	Standard	Title
Electrical Safety *	AS/NZS 60065	Audio, video and similar electronic apparatus - Safety requirements
EMC	AS/NZS CISPR 13	Sound and television broadcast receivers and associated equipment - Radio disturbance characteristics (emissions)

When powered by EP1096 or PAC090M Power Supply, Clipsal Catalogue Number 5600P24H3750A or 5600P24/3750AU. The power supply meets the following safety standards: IEC 60065 and 60950, EN 60065 and 60950, K60950, J60950 (H14), CNS 13438, CAN/CSA C22.2 No's. 60950-1 and 60065-03, UL 60065 and 60950-1 (UL file 161451)

The power supply meets the following EMC standards: EN 55013, 55020, 61000-3-2 and 61000-3-3

European Directives and Standards



European Council Directive	Standard	Title
2004/108/EC	EN 55013	Sound & TV Broadcast receivers & associated equip. – Radio Disturbance Characteristics
	EN 55020	Sound & TV Broadcast receivers & associated equip. – Immunity Characteristics – Limits & Methods of Measurement
RoHS 2002/95/EC		Reduction of hazardous substances

Other International Directives and Standards

Directive	Standard	Title
2004/108/EC	CISPR 13	Sound & TV Broadcast receivers & associated equip. – Radio Disturbance Characteristics
	CISPR 20	Sound & TV Broadcast receivers & associated equip. – Immunity Characteristics – Limits & Methods of Measurement

9 Two-Year Warranty

The C-Bus Multi Room Audio Amplifier carries a two-year warranty against manufacturing defects.

Warranty Statement

The benefits conferred herein are in addition to, and in no way shall be deemed to derogate; either expressly or by implication, any or all other rights and remedies in respect to the Schneider Electric product, which the consumer has in the location where the product is sold.

The warrantor is Schneider Electric with offices worldwide.

This Schneider Electric product is guaranteed against faulty workmanship and materials for a period of two (2) years from the date of installation.

Schneider Electric reserves the right, at its discretion, to either repair free of parts and labour charges, replace or offer refund in respect to any article found to be faulty due to materials, parts or workmanship.

This warranty is expressly subject to the Schneider Electric product being installed, wired, tested, operated and used in accordance with the manufacturer's instructions. Any alterations or modifications made to the product without permission of Schneider Electric might void the warranty.

Schneider Electric shall meet all costs of a claim. However, should the product that is the subject of the claim be found to be in good working order, all such costs shall be met by the claimant.

When making a claim, the consumer shall forward the Schneider Electric product to the nearest Schneider Electric office. Provide adequate particulars of the defect within 28 days of the fault occurring. The product should be returned securely packed, complete with details of the date and place of purchase, description of load, and circumstances of malfunction.

For all warranty enquiries, contact your local Clipsal sales representative. The address and contact number of your nearest sales office can be found at <http://www.clipsal.com/locations> or by telephoning Clipsal CIS Technical Support 1300 722 247 (CIS Technical Support Hotline).

Technical Support

For further assistance in using this product, consult your nearest Clipsal Integrated Systems (CIS) Sales Representative or Technical Support Officer.

Technical Support Contact Numbers	
Australia	1300 722 247 (CIS Technical Support Hotline)
New Zealand	0800 888 219 (CIS Technical Support Hotline)
Northern Asia	+852 2484 4157 (Clipsal Hong Kong)
South Africa	011 314 5200 (C-Bus Technical Support)
Southern Asia	+603 7665 3555 Ext. 236 or 242 (CIS Malaysia)
United Kingdom	0870 608 8 608 (Schneider Electric Support)

Technical Support email: cis.support@clipsal.com.au

Clipsal Australia Pty Ltd

A member of Schneider Electric

clipsal.com

Contact us clipsal.com/feedback

National Customer Care Enquiries:

Tel 1 300 202 525

Fax 1 300 202 556



F2235

Schneider Electric reserves the right to change specifications, modify designs and discontinue items without incurring obligation and whilst every effort is made to ensure that descriptions, specifications and other information in this catalogue are correct, no warranty is given in respect thereof and the company shall not be liable for any error therein.

Copyright by Schneider Electric. All rights reserved.

CPL000095