

C-Bus[®]**C-Bus 30M Mechanism****Installation Instructions****5031NMx Series**

Figure 1. Top and bottom views of the master mechanism

The C-Bus master mechanism is a C-Bus key input unit that is assigned a unique unit address on the network. The 5031NMMIRL master unit has an infrared receiver for use with IR remote control units

Catalogue Number	Description
5031NMMIRL	IR capable C-Bus master mechanism for Clipsal 30 Series aperture grid plates and enclosures
5031NMML	C-Bus master mechanism for Clipsal 30 series aperture grid plates and enclosures
5031NMS	C-Bus slave mechanism for Clipsal 30 series aperture grid plates and enclosures

The maximum configuration is one master mechanism and three slave units. The minimum configuration is a master mechanism.

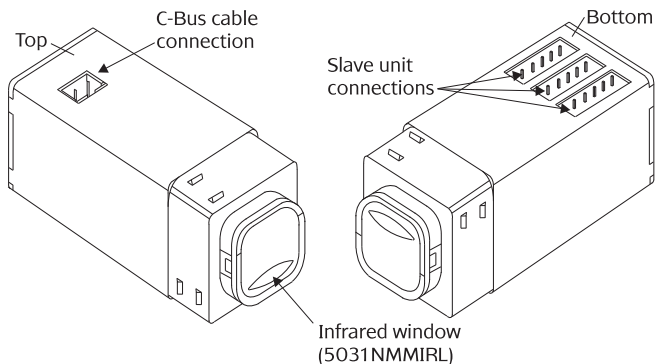
The 30M master mechanism is a control switch only. It is never connected to building power directly. The C-Bus network uses unshielded twisted pair (UTP) Category 5 (Cat.5e) cable. The C-Bus network powers the master mechanism. Both master and slave units have LED indicator lights. The indicators in the slave units are powered from the master unit.

Optional slave mechanisms have multiple wires with a female connector that attaches to a socket in the master unit.

Non-adhesive labels on a pre-cut sheet are included with master switch mechanisms. The label must not cover the IR window of a 5031NMMIRL master unit.

C-Bus Toolkit software is used to program the master mechanism and its associated slave switches. Using software not provided by Clipsal Integrated Systems may void any warranties applicable to the hardware.

1.0 Installation

Selecting a Suitable Mounting Location

It is important to select the right location to install the wall switch. Some considerations are listed below:

- Units are designed for indoor use only, unless installed in an appropriate IP rated enclosure.
- Provide easy access to the unit for switching lights and selecting scenes.
- Choose a location free of water, humidity and direct sunlight.
- Allow adequate ventilation.
- Units may be mounted vertically or horizontally.

Multiple IR wall switches can be installed on a C-Bus network. These units may be programmed to operate cooperatively or independently of each other.

Take care not to mount units where a single IR remote control transmission can be received by multiple units (illustrated in Figure 2). Multiple units may trigger a scene, with unpredictable results.

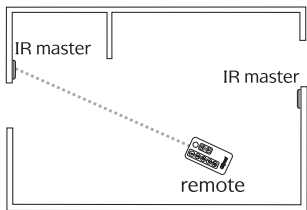

Good placement

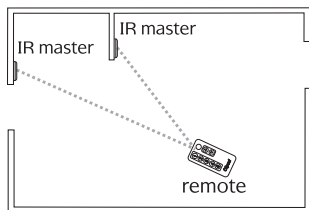

Not recommended

Figure 2. Placement of multiple 5031NMMIRL wall switches

Installing Labels and Button Covers

Install the supplied labels before installing master or slave mechanisms in the grid plate. Use labels with cut out areas for the 5031NMMIRL.

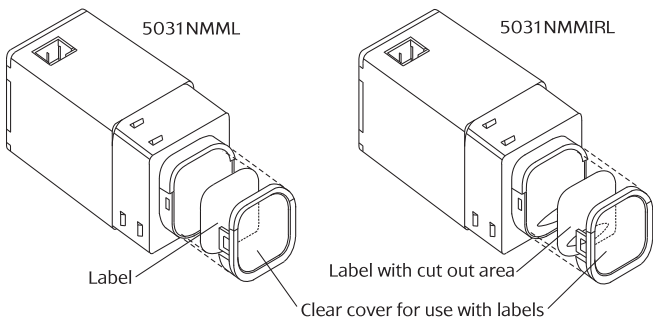

Figure 3. Installing the label and cover.

Assembling the 30M mechanisms on the Grid Plate

Install the slave units below the master mechanism when possible. The units can be placed in any open location in the grid panel.

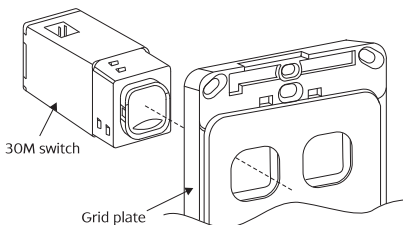

Figure 5. Installing the mechanism in the grid plate

Connecting Slave Units to the Master

Attach up to three slave units to the master unit using the ribbon cables that are integral to the slaves. When removing a connector from the master unit, pull on the connector not the ribbon cable.

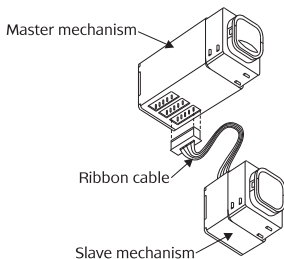

Figure 6. Connecting the slave wiring to the master

Connecting the C-Bus Network Cable



Never connect the C-Bus master mechanism to building power. The unit is a network input device. It uses Category 5 (Cat.5e), unshielded twisted pair network cable, Clipsal catalogue number 5005C305B (solid) or 5005C305BST (stranded).

A cable is supplied to connect the master unit to the C-Bus network cable. Be sure to connect the C-Bus + to the terminal marked + and connect the C-Bus - wires to the terminal marked -. Refer to Figures 7 and 8.

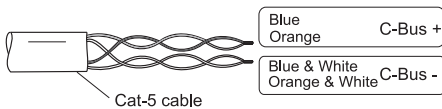

Figure 7. C-Bus cable conductor assignments

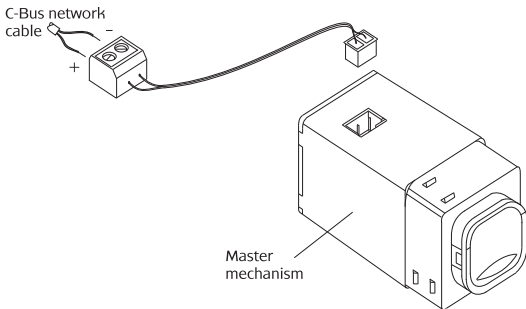

Figure 8 – Master switch to the C-Bus network

2.0 C-Bus Requirements

Programming

C-Bus master wall switches are learn enabled devices. This means you can create relationships between input and output units without a computer (using learn mode).

Learn mode allows you to link multiple units into a common network. You can assign a load such as a light on a dimmer unit, with a controller such as a wall switch, by touching the two units one after the other.

In a sophisticated installation, some of the basic settings created by learn mode may need to be overridden to create a particular effect. The latest C-Bus Toolkit software may be downloaded from the Clipsal Integrated Systems website (www.clipsal.com).

C-Bus power

A C-Bus master unit always draws 18 mA from the C-Bus network, regardless of the number of slaves connected. Adequate C-Bus Power Supply Units must be installed to support the connected devices.

The Network window of a C-Bus Toolkit project provides a summary of a C-Bus network according to the units added to the Database. This can be helpful in determining the power supply requirements of a particular network.

3.0 Electrical Specifications

Parameter	Description
C-Bus supply voltage	15 to 36 V d.c.
Power requirement	18 mA. The switch does not provide current to the C-Bus network.
C-Bus AC input impedance	100 k Ω @ 1 kHz
Maximum number of units per network	100
Control functions	Load switching, dimming, timers, scene control
Status indicators	User configurable, orange or blue
Warm-up time	5 seconds
C-Bus connection	Twisted pair, UTC Cat.5e
Operating temperature range	0 to 45 °C
Operating humidity range	10 to 95% RH

4.0 Mechanical Specifications

Parameter	Master	Slave
Dimensions (W×H×D)	23 mm x 23 mm x 41 mm	23 mm x 23 mm x 20 mm
Protrusion from wall	Depends on grid plate and surround selected	Depends on grid plate and surround selected
Weight	13 g	7 g

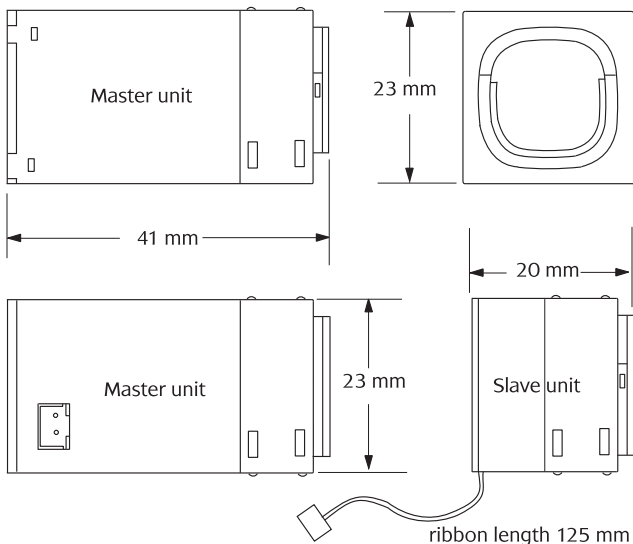

5.0 Standards Complied

The 5031 Series 30M mechanisms products comply with the following:

Australian/New Zealand EMC & Electrical Safety Frameworks and Standards

Regulation	Standard	Title
EMC	AS/NZS CISPR 14-1 AS/NZS CISPR 15	RFI Emissions RFI Emissions

European Directives and Standards

EC Directive	Standard	Title
EMC Directive 2004/108/EC	EN55014-1	Electrical Motor-operated and Thermal Appliances
	EN60669-2-1 Clause 26-1 EN60669-2-1 Clause 26-2	Switches for Household and Similar Fixed Electrical Installations
	EN55015	Limits for Harmonics

Other International Directives and Standards

Regulation	Standard	Title
EMC	IEC 60669-2-1 Clause 26	RF and Low Frequency Emissions

USA Standards

Standard
US FCC Part 15, Subpart B – Radio Frequency Devices – Unintentional Radiators

6.0 Warranty

C-Bus 5031NM series wall switches carry a two-year warranty against manufacturing defects.

Warranty Statement

- 1) The benefits conferred herein are in addition to, and in no way shall be deemed to derogate; either expressly or by implication, any or all other rights and remedies in respect to Clipsal Integrated Systems Product, which the consumer has under the Commonwealth Trade Practices Act or any other similar State or Territory Laws.
- 2) The warrantor is Clipsal Australia Pty Ltd, with registered offices in all Australian States.
- 3) This Clipsal Integrated Systems Product is guaranteed against faulty workmanship and materials for a period of two (2) years from the date of installation.
- 4) Clipsal Australia Pty Ltd reserves the right, at its discretion, to either repair free of parts and labour charges, replace or offer refund in respect to any article found to be faulty due to materials, parts or workmanship.
- 5) This warranty is expressly subject to the Clipsal Integrated Systems Product being installed, wired, tested, operated and used in accordance with the manufacturer's instructions.
- 6) All costs of a claim shall be met by Clipsal Australia Pty Ltd, however should the product that is the subject of the claim be found to be in good working order, all such costs shall be met by the claimant.
- 7) When making a claim, the consumer shall forward the Clipsal Integrated Systems Product to the nearest office of Clipsal Australia Pty Ltd with adequate particulars of the defect within 28 days of the fault occurring. The product should be returned securely packed, complete with details of the date and place of purchase, description of load, and circumstances of malfunction.

For all warranty enquiries, contact your local Clipsal sales representative.

7.0 Technical Support and Troubleshooting

For further assistance in using this product, consult your nearest Clipsal Integrated Systems (CIS) Sales Representative or Technical Support Officer.

Technical Support Contact Numbers	
Australia	1300 722 247 (CIS Technical Support Hotline)
New Zealand	0800 888 219 (CIS Technical Support Hotline)
Northern Asia	+852 2484 4157 (Clipsal Hong Kong)
South Africa	011 314 5200 (C-Bus Technical Support)
Southern Asia	+603 7665 3555 Ext. 236 or 242 (CIS Malaysia)
United Kingdom	0870 608 8 608 (Schneider Electric Support)

Technical Support email: cis_support@clipsal.com.au

Product of Clipsal Australia Pty Ltd

A member of Schneider Electric
Contact us: clipsal.com/feedback

clipsal.com

National Customer

Care Enquiries

Tel 1300 2025 25

Fax 1300 2025 56

Clipsal Australia Pty Ltd reserves the right to change specifications, modify designs and discontinue items without incurring obligation and whilst every effort is made to ensure that descriptions, specifications and other information in this document are correct, no warranty is given in respect thereof and the company shall not be liable for any error therein.