

CLIPSAL[®]
LIVING ELECTRICAL

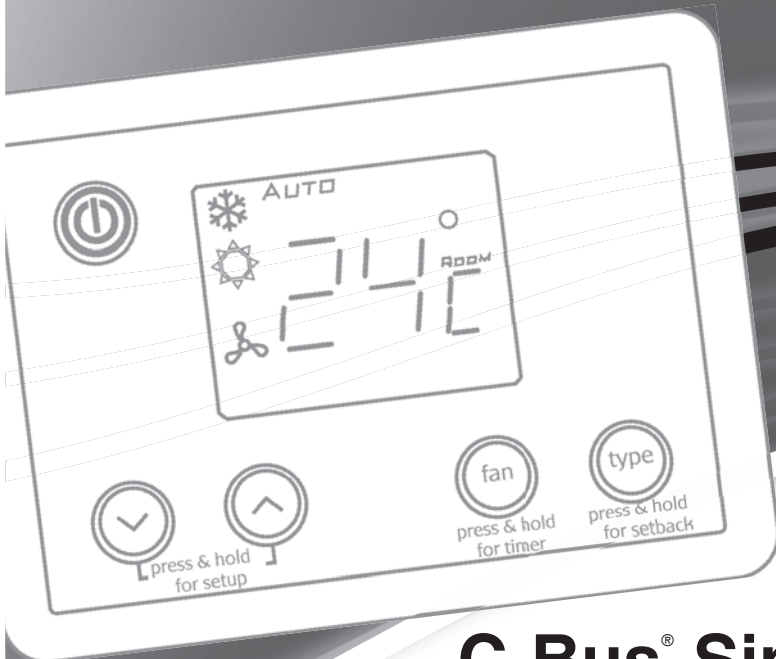

C-Bus[®]

C-Bus[®] Single Zone Thermostat

5070THB Series



Installation Instructions

REGISTERED DESIGN • REGISTERED PATENT

Clipsal is a registered trademark of Clipsal Australia Pty Ltd ABN 27 007 873 529.

© Copyright Clipsal Australia Pty Ltd 2008. All rights reserved. This material is copyright under Australian and international laws. Except as permitted under the relevant law, no part of this work may be reproduced by any process without prior written permission of and acknowledgement to Clipsal Australia Pty Ltd.

The information in this manual is provided in good faith. Whilst Clipsal Australia Pty Ltd (CAPL) has endeavoured to ensure the relevance and accuracy of the information, it assumes no responsibility for any loss incurred as a result of its use. CAPL does not warrant that the information is fit for any particular purpose, nor does it endorse its use in applications that are critical to the health or life of any human being. CAPL reserves the right to update the information at any time without notice.

Contents

1.0	Product Range	5
2.0	Important Notes	5
3.0	Description	5
4.0	Installation Considerations	7
5.0	Mounting Instructions	7
6.0	C-Bus Network Connection	9
7.0	C-Bus Power Requirements	9
8.0	HVAC Connection	10
9.0	Megger Testing	13
10.0	C-Bus Programming	14
11.0	Electrical Specifications	15
12.0	Mechanical Specifications	16
13.0	Standards Complied	17
14.0	Warranty	19

1.0 Product Range

Catalogue No.	Product
5070THB	C-Bus Single Zone Thermostat
5070THBR	C-Bus Single Zone Thermostat with Built-in HVAC Control Relay

2.0 Important Notes

- Ensure the temperature sensor is mounted in a position suitable for measuring the environment being temperature controlled. This applies to the 5070THB Series' internal sensor or to an external C-Bus temperature sensor (whichever is utilised).
- A C-Bus network must be connected to the 5070THB Series unit, to provide power and a C-Bus system clock.
- When the 5070THB Series unit is connected to HVAC equipment, do not press the power button until C-Bus programming is complete.

3.0 Description

The 5070THB Series C-Bus Single Zone Thermostat is used to control heating/ventilation/air conditioning (HVAC) equipment, regulating the air temperature of a particular environment.

The 5070THBR model has built-in relays that can be connected to HVAC equipment that uses a standard 24 V AC RWG interface. The 5070THB model connects to HVAC equipment via an external C-Bus Relay unit (such as the 5508RVF). Apart from this, both models have the same features.

The air temperature is monitored by the unit's internal temperature sensor or optionally via an external C-Bus temperature sensor.

Figure 1 shows the system connection of a 5070THBR. A 5500PS C-Bus Power Supply is used to provide a basic C-Bus network.

In Figure 2, a 5508RVF C-Bus Voltage Free Relay is used to provide the C-Bus power supply, system clock and burden for the 5070THB. It also provides the relays that interface with the HVAC equipment.

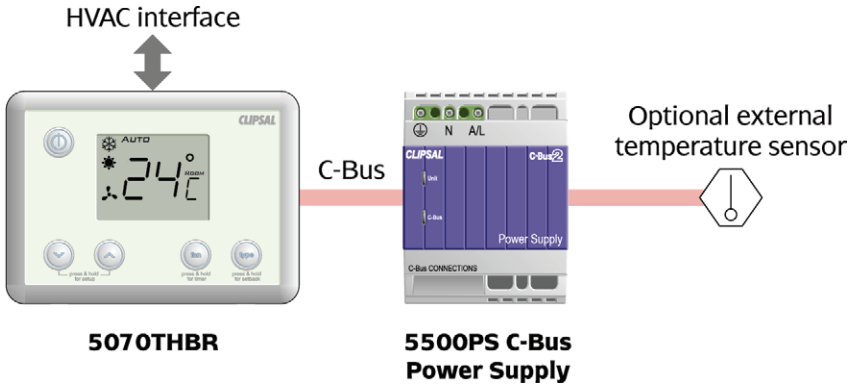

Figure 1 - The 5070THBR has built-in relays to connect to an HVAC system

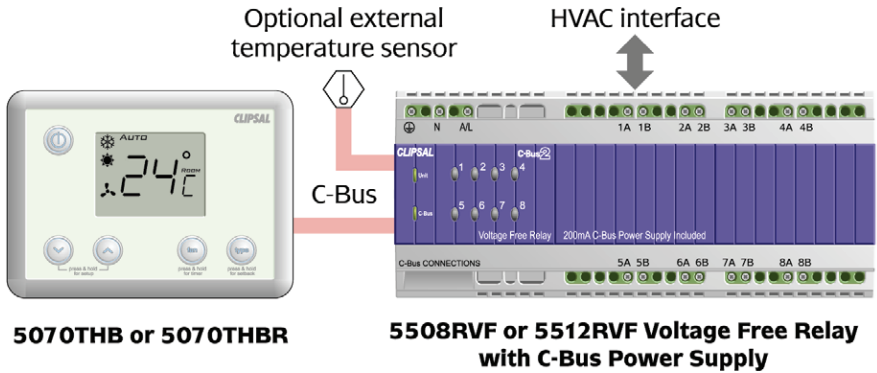

Figure 2 - The 5070THB connects to an HVAC system via external C-Bus relays

4.0 Installation Considerations

It is important to select the right location to install the 5070THB Series C-Bus Single Zone Thermostat, particularly if the internal temperature sensor is used. Some considerations are listed below:

- Provide easy access to the unit for operation by the user.
- Choose a location free of water, high humidity, direct sunlight and heavy dust. Avoid close proximity to HVAC outlets.
- Do not cover the unit or block its air vents.
- The C-Bus Single Zone Thermostat is designed for indoor use only.
- Ensure the unit (if the internal temperature sensor is used) or external temperature sensor is mounted in a position suitable for measuring the environment being temperature controlled.



no wet
hands



no cleaner
spray



no
coverage



no direct
sunshine



no
dust

5.0 Mounting Instructions

It is recommended you use a standard 84 mm centre mounting C-Clip or wall box (such as the Clipsal E157) to mount the 5070THB or 5070THBR. Alternatively, surface mount the unit using appropriate fixing hardware. Do not recess the unit into a wall, as the side air vents must be exposed.

Mounting diagrams are provided in Figures 3 and 4. To mount the unit:

- 1) Insert a flat head screw driver into the notches at the bottom of the Thermostat and gently pry the base plate off the unit.
- 2) Prepare the mounting surface using a wall box, C-Clip, or other fixing hardware.
- 3) Place the base plate over the C-Clip or wall box, and feed the cables through.
- 4) Screw the base plate to the mounting surface.
- 5) Wire the appropriate conductors to the terminals.
- 6) Align the Thermostat over the base plate and push to reattach.

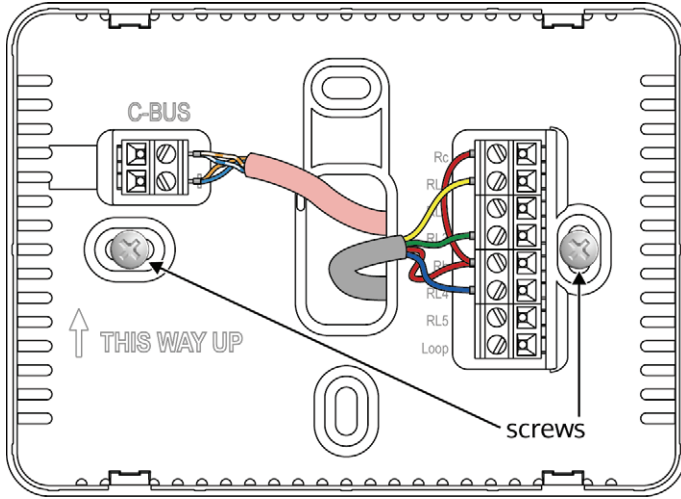

Figure 3 - Mounting the 5070THBR base plate (C-Bus and example HVAC wiring)



NOTE

HVAC relay terminal wiring will vary depending on the HVAC system installed.

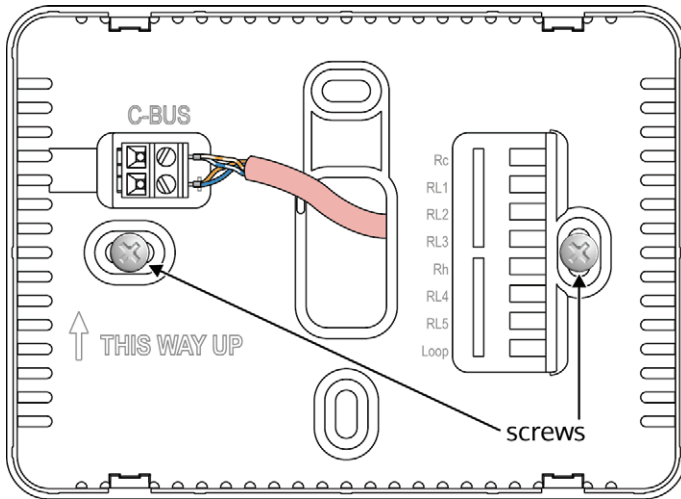
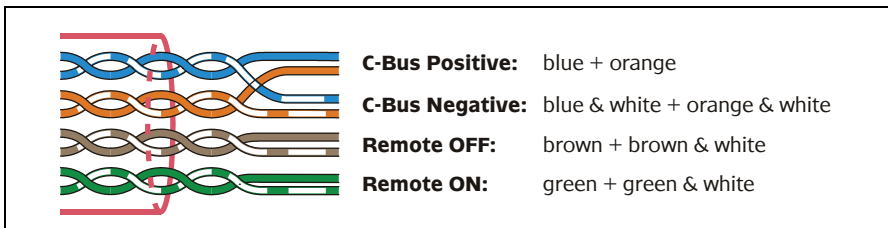

Figure 4 - Mounting the 5070THB base plate (C-Bus wiring)

6.0 C-Bus Network Connection

Connection to the C-Bus network is made via the dual terminal connector on the inside of the base plate. Use Cat-5 Unshielded Twisted Pair (UTP) C-Bus cable. The use of bootlace ferrules (crimps) is recommended for reliable connection.

C-Bus cable conductor assignments and connector pinouts are shown below. The Remote ON and Remote OFF conductors are not connected to this unit. The Clipsal catalogue number for the C-Bus Cat-5 UTP cable is 5005C305B.



	Terminal	C-Bus Connection	Conductors
		C-Bus Negative (-)	blue & white
			orange & white
		C-Bus Positive (+)	blue
orange			

7.0 C-Bus Power Requirements

5070THB Series C-Bus Single Zone Thermostats draw 40 mA from the C-Bus network. Adequate C-Bus Power Supply Units must be installed to support connected devices. The Network window of a C-Bus Toolkit project provides a summary of a C-Bus network according to the units added to the Database. This can be helpful in determining the power supply requirements of a particular network.

8.0 HVAC Connection



WARNING

Incorrect wiring of the HVAC equipment could cause damage to the HVAC equipment or 5070THB Series unit. Refer to the HVAC installation instructions before connecting.

There are two stages in interfacing the 5070THB Series C-Bus Single Zone Thermostat with HVAC equipment; the physical wiring and C-Bus programming.

The Thermostat can be wired to HVAC equipment that uses a standard air conditioning RWG/RWGY control interface. It can also be wired to some other HVAC systems, depending on their wiring (refer to the manufacturer’s wiring diagram or application notes).

Connection scenarios for standard RWG/RWGY systems are provided in Figure 5 to Figure 9. They use a 5070THBR (with built-in relays). In each case a 5070THB and C-Bus Voltage Free Relay combination may be used instead. The 5070THBR provides 5 × relay channels (RL1, RL2 and RL3 looped to Rc; RL4 and RL5 looped to Rh). An external C-Bus Voltage Free Relay may be used to provide any additional relay channels.

These scenarios are examples only; refer to the HVAC installation instructions for wiring details specific to your system.

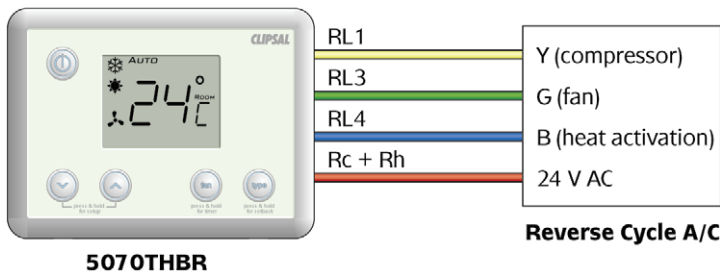

Figure 1 - Connecting to a reverse cycle A/C that uses RWG control

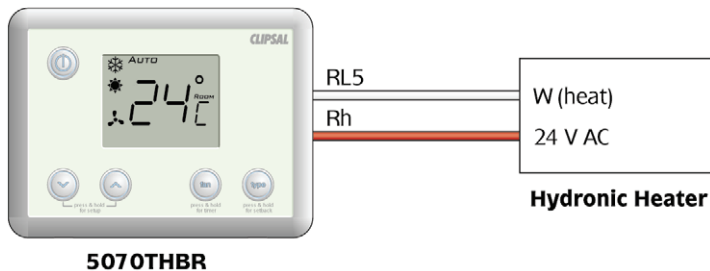

Figure 6 - Connecting to a hydronic heating system that uses RWG control

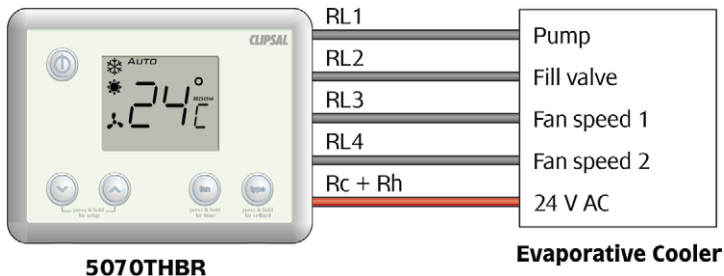

Figure 7 - Connecting to an evaporative cooler that uses RWG control

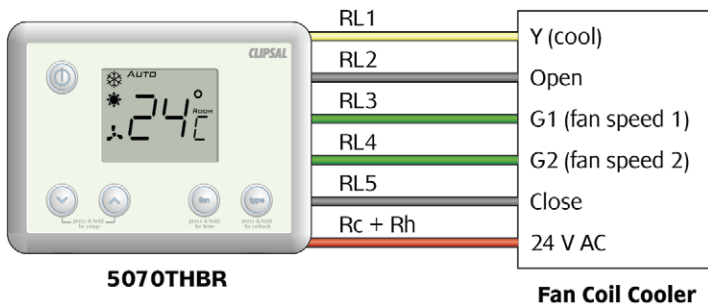

Figure 8 - Connecting to a fan coil cooling system which uses RWG control

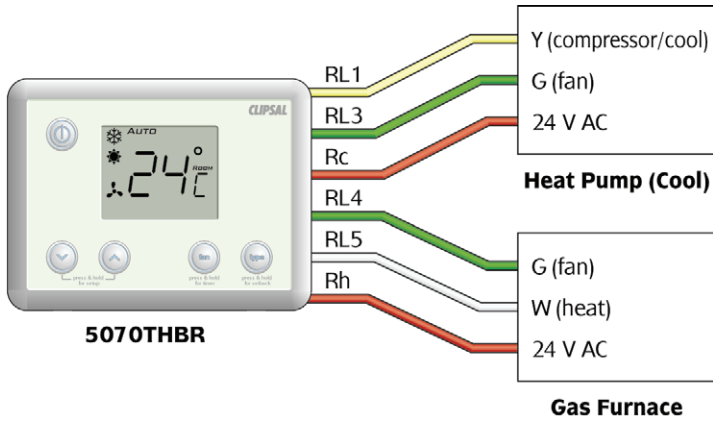

Figure 9 - Connecting to separate RWG based cooling and heating systems

Figure 10 and Figure 11 show the interfacing of a fan coil A/C system that does **not** use standard RWG control.

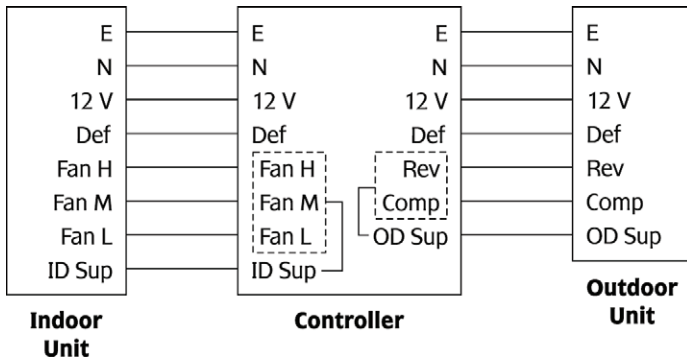

Figure 10 - An example A/C system without standard RWG control

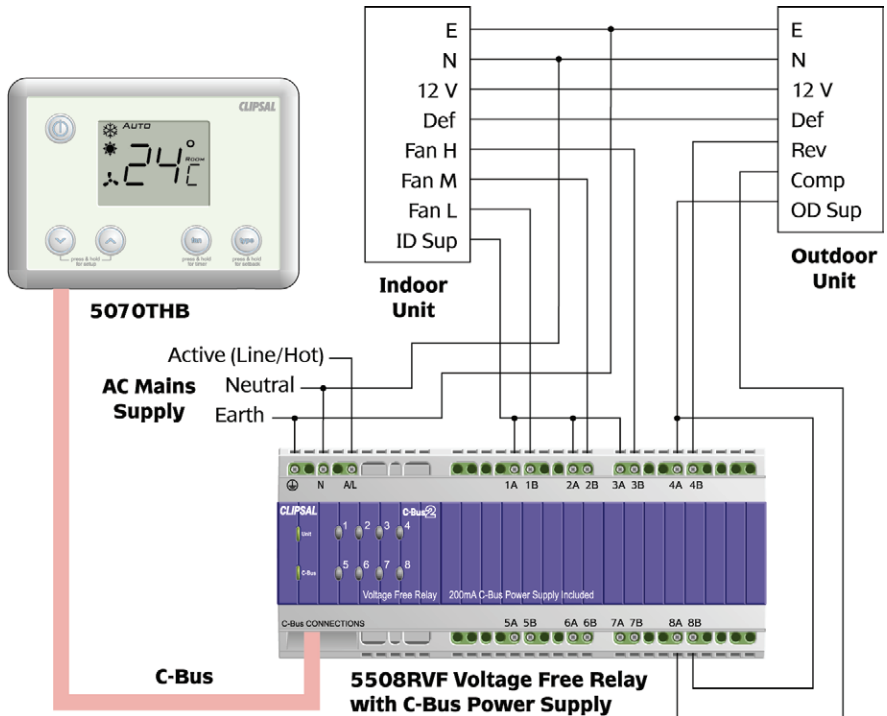

Figure 11 - Connecting to the A/C system shown in Figure

9.0 Megger Testing

Important points when megger testing an electrical installation:

- Only megger test when mains cabling is disconnected from C-Bus output units.
- Do not megger test the C-Bus cable.

10.0 C-Bus Programming



WARNING

Incorrect programming of the 5070THB Series C-Bus Single Zone Thermostat could cause damage to the 5070THB unit or HVAC equipment.

When the 5070THB Series unit is connected to HVAC equipment, do not press the power button until C-Bus programming is complete.

Before the 5070THB Series C-Bus Single Zone Thermostat can be used to control the HVAC system, it must be configured using C-Bus Toolkit software. C-Bus Toolkit is available from the Downloads section of the Clipsal Integrated Systems (CIS) web site (<http://www.clipsal.com/cis>).

Using C-Bus Toolkit, you must:

- give the Thermostat a unique unit address
- configure the Plant settings; including groups for the internal relays (5070THBR model), fan control, cooling, heating, etc. appropriate for the plant type
- configure the Temperature Control settings.

You can also customise various settings on the User Interface and Temperature Control tabs, such as backlight levels, and temperature guard settings.

Refer to C-Bus Toolkit Help documentation for information on the settings (click the Help button from the relevant tab when editing the Thermostat within Toolkit).

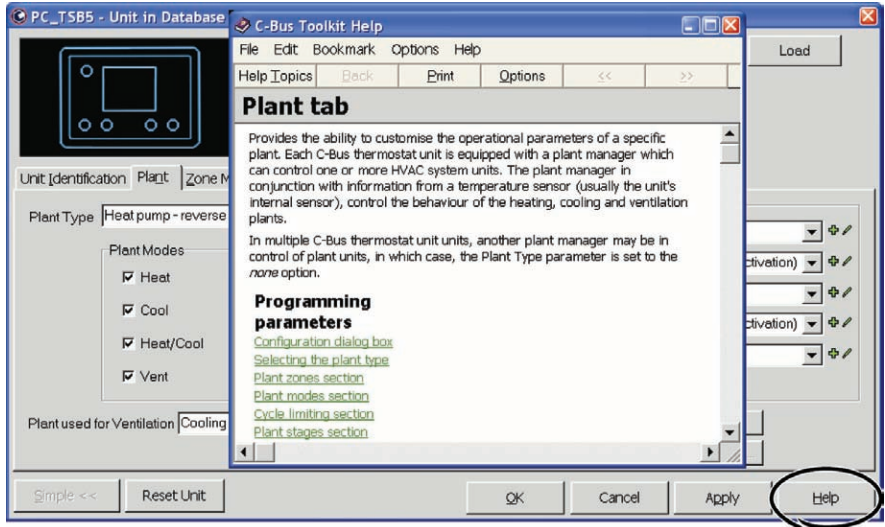

Figure 12 - Click the Help button for help with configuring the tab's settings

11.0 Electrical Specifications

Parameter	Description
C-Bus supply voltage	15 to 36 V DC, 40 mA Does not provide current to the C-Bus network
C-Bus AC input impedance	50 k Ω @ 1 kHz
Relays (5070THBR model)	Each relay rated at 2 A @ 24 V AC
C-Bus connection	One terminal block to accommodate 0.2 to 1.3 mm ² (24 to 16 AWG)
Temperature sensor accuracy	+/- 0.5 °C (+/- 0.9 °F)
Operating temperature	- 10 to 50 °C (14 to 122 °F)
Operating humidity	10 to 95% RH

12.0 Mechanical Specifications

Parameter	Description
Dimensions (W × H × D)	127 × 92 × 27 mm
Mounting Centres	84 mm (horizontal) 60.3 mm (vertical)
Weight (models with stainless steel facia)	5070THBSS: 265 g 5070THBRSS: 280 g

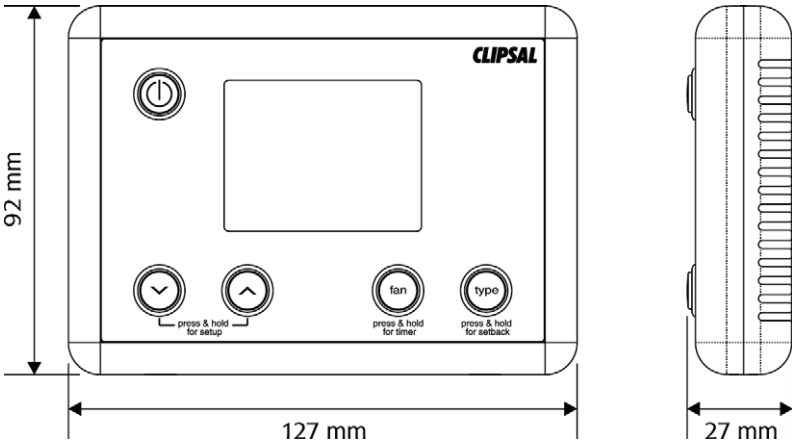

13.0 Standards Complied

DECLARATIONS OF CONFORMITY

Australian/New Zealand EMC & Electrical Safety Frameworks and Standards

Model 5070THB and 5070THBR products comply with the following:

Australian/New Zealand EMC & Electrical Safety Frameworks and Standards



Regulation	Standard	Title
EMC	AS/NZS CISPR 14-1	Electromagnetic compatibility – Requirements for household appliances, electric tools and similar apparatus – Part 1: Emission
	AS/NZS CISPR 15	Limits and methods of measurement of radio disturbance characteristics of electrical lighting and similar equipment
	AS/NZS CISPR22	Information technology equipment – Radio disturbance characteristics – Limits and methods of measurement

European Directives and Standards



Regulation	Standard	Title
EMC Directive 2004/108/EC	EN60669-2-1 Clause 26.1	Immunity to ESD, RFI, EFT, Surge Voltages, Voltage Dips and Interruptions
	EN 6069-2-1 Clause 26.2	RF and Low Frequency Emissions
	EN 55014-1	Electromagnetic compatibility – Requirements for household appliances, electric tools and similar apparatus – Emissions
	EN 55015	Limits and methods of measurement of radio disturbance characteristics of electrical lighting and similar equipment
	EN 55022	Information technology equipment – Radio disturbance characteristics – Limits and methods of measurement

US FCC Regulations

Regulation	Title
FCC Part 15, Subart B	Radio Frequency Devices – Unintentional Radiators

Supplemental Information

This device complies with Part 15 of the FCC Rules. Operation is subject to the following two conditions: (1) this device may not cause harmful interference, and (2) this device must accept any interference received, including interference that may cause undesirable operation.

Class B Product

NOTE: This equipment has been tested and found to comply with the limits for a Class B digital device, pursuant to Part 15 of the FCC Rules. These limits are designed to provide reasonable protection against interference in a residential installation. This equipment generates, uses and can radiate radio frequency energy and, if not installed and used in accordance with the instructions, may cause harmful interference to radio communications. However there is no guarantee that interference will not occur in a particular installation. If this equipment does cause harmful interference to radio or television reception, which can be determined by turning the equipment off and on, the user is encouraged to try to correct the interference by one or more of the following measures:

- reorient or relocate the receiving antenna
- increase the separation between the equipment and receiver
- connect the equipment into an outlet on a circuit different from that to which the receiver is connected
- consult the dealer or an experienced radio/TV technician for help.

Other International Directives and Standards

Regulation	IEC Standard	Title
EMC	IEC 60669-2-1 Clause 26 CISPR 14-1	RF and Low Frequency Emissions Electromagnetic compatibility – Requirements for household appliances, electric tools and similar apparatus – Part 1: Emissions
	CISPR 15	Limits and methods of measurement of radio disturbance characteristics of electrical lighting and similar equipment
	CISPR 22	Information technology equipment – Radio disturbance characteristics – Limits and methods of measurement

14.0 Warranty

5070THB Series C-Bus Single Zone Thermostats carry a two-year warranty against manufacturing defects.

Warranty Statement

- 1) The benefits conferred herein are in addition to, and in no way shall be deemed to derogate; either expressly or by implication, any or all other rights and remedies in respect to Clipsal Integrated Systems Product, which the consumer has under the Commonwealth Trade Practices Act or any other similar State or Territory Laws.
- 2) The warrantor is Clipsal Pty Ltd, with registered offices in all Australian States.
- 3) This Clipsal Integrated Systems Product is guaranteed against faulty workmanship and materials for a period of two (2) years from the date of installation.
- 4) Clipsal Australia Pty Ltd reserves the right, at its discretion, to either repair free of parts and labour charges, replace or offer refund in respect to any article found to be faulty due to materials, parts or workmanship.
- 5) This warranty is expressly subject to the Clipsal Integrated Systems Product being installed, wired, tested, operated and used in accordance with the manufacturer's instructions.
- 6) All costs of a claim shall be met by Clipsal Australia Pty Ltd, however should the product that is the subject of the claim be found to be in good working order, all such costs shall be met by the claimant.
- 7) When making a claim, the consumer shall forward the Clipsal Integrated Systems Product to the nearest office of Clipsal Australia Pty Ltd with adequate particulars of the defect within 28 days of the fault occurring. The product should be returned securely packed, complete with details of the date and place of purchase, description of load, and circumstances of malfunction.

For all warranty enquiries, contact your local Clipsal sales representative. The address and contact number of your nearest Clipsal Australia office can be found at <http://www.clipsal.com/locations> or by telephoning Technical Support 1300 722 247 (CIS Technical Support Hotline).

Technical Support and Troubleshooting

For further assistance in using this product, consult your nearest Clipsal Integrated Systems (CIS) Sales Representative or Technical Support Officer.

Technical Support Contact Numbers	
Australia	1300 722 247 (CIS Technical Support Hotline)
New Zealand	0800 888 219 (CIS Technical Support Hotline)
Northern Asia	+852 2484 4157 (Clipsal Hong Kong)
South Africa	011 314 5200 (C-Bus Technical Support)
Southern Asia	+603 7665 3555 Ext. 236 or 242 (CIS Malaysia)
United Kingdom	0870 608 8 608 (Schneider Electric Support)

Technical Support Email: tech.training@clipsal.com.au

Product of Clipsal Australia Pty Ltd

A member of Schneider Electric

Contact us: clipsal.com/feedback

National Customer Service Enquiries:

Tel 1300 2025 25

Fax 1300 2025 56

clipsal.com

Clipsal Australia Pty Ltd reserves the right to change specifications, modify designs and discontinue items without incurring obligation and whilst every effort is made to ensure that descriptions, specifications and other information in this catalogue are correct, no warranty is given in respect thereof and the company shall not be liable for any error therein.

© Clipsal Australia Pty Ltd. The identified trademarks and copyrights are the property of Clipsal Australia Pty Ltd unless otherwise noted.