

**CLIPSAL**<sup>®</sup>

by **Schneider** Electric

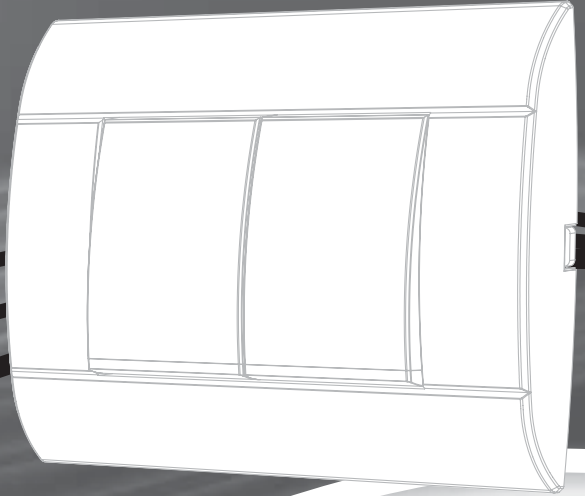

**C-Bus**<sup>®</sup>

**Large Rocker Switch**

**509xNL**

509xNL Series



Installation Instructions

# Contents

- 1.0 Product Range .....3**
- 2.0 Important Notes .....3**
- 3.0 Description .....3**
- 4.0 Installation Considerations .....4**
- 5.0 Mounting Instructions..... 4-5**
- 6.0 C-Bus Network Connection ..... 5-6**
- 7.0 C-Bus Power Requirements.....7**
- 8.0 Megger Testing.....7**
- 9.0 Programming Requirements .....7**
- 10.0 Electrical Specifications .....8**
- 11.0 Mechanical Specifications .....9**
- 12.0 Standards Complied..... 10**
- 13.0 Warranty ..... 11**

## 1.0 Product Range

**5091NL,WE** 1 Button C-Bus Large Rocker Switch

**5092NL,WE** 2 Button C-Bus Large Rocker Switch

**5093NL,WE** 3 Button C-Bus Large Rocker Switch

## 2.0 Important Notes

- Do not connect mains to C-Bus Large Rocker Switches.
- The use of any software not provided by Clipsal Integrated Systems (CIS) in conjunction with the installation of this product, may void any warranties applicable to the hardware.

## 3.0 Description

The 509xNL C-Bus Large Rocker Switch is an accessible C-Bus wall switch range suitable for people with a disability and aged care applications.

Units feature up to three buttons, scene management and learn mode capability.

## 4.0 Installation Considerations

It is important to select the right location to install a C-Bus Large Rocker switch. Some considerations:

- Provide easy access to the unit for switching lights and selecting scenes.
- Choose a location free of water, excess humidity, prolonged direct sunlight and heavy dust.
- C-Bus Large Rocker switches are designed for indoor use only.
- Units are normally mounted horizontally.

## 5.0 Mounting Instructions

There are several options for mounting a C-Bus Large Rocker switch. You can:

- Use a wall box (in solid or stud walls)
- Use a c-clip or mounting flange (in stud/plasterboard walls)
- Screw directly into wall plugs.

C-Bus Large Rocker Switches suit standard 84 mm centre mounting accessories such as the Clipsal 155 and 157/1. Mounting using a c-clip is shown in Figure 1. Mounting using a 157/1 wall box is shown in Figure 2.

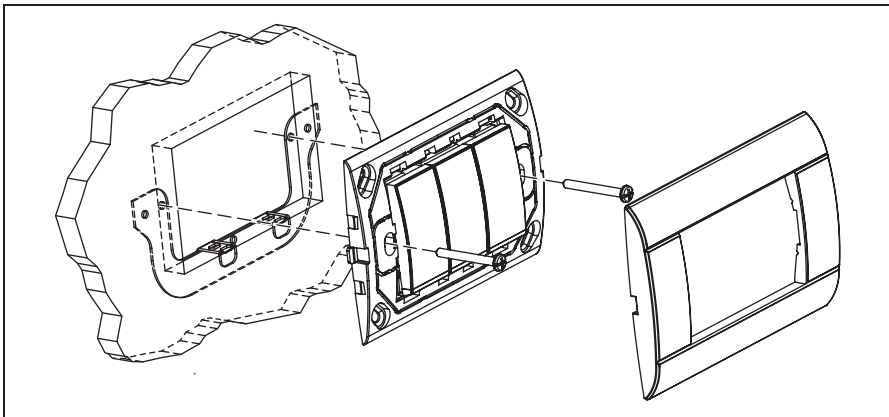

Figure 1 - Mounting a C-Bus Large Rocker Switch using a c-clip

## 5.0 Mounting Instructions

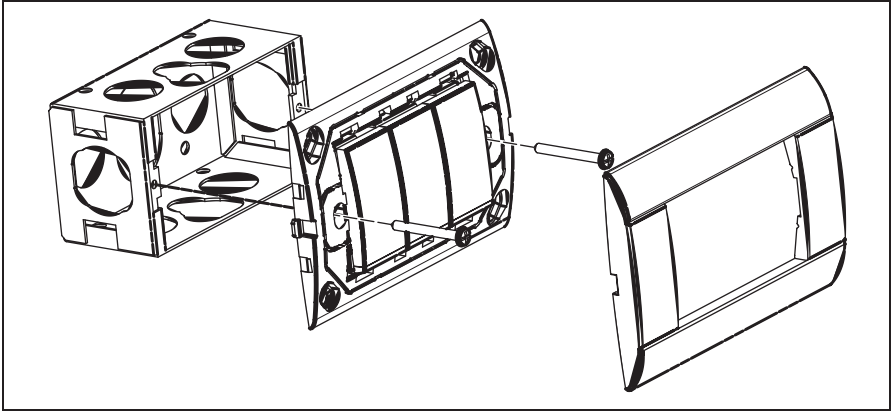

Figure 2 - Mounting a C-Bus Large Rocker Switch using a 157/1 wall box

## 6.0 C-Bus Network Connection

Installation of a C-Bus Large Rocker Switch on the C-Bus network requires connection to the unshielded twisted pair C-Bus cable. Connection should be made using Category 5 (Cat-5) data cable, Clipsal catalogue number 5005C305B.

Figure 3 and Table 1 identify the connections required between the C-Bus Cat-5 cable and 509xNL switch. Terminal locations are shown in Figure 5.

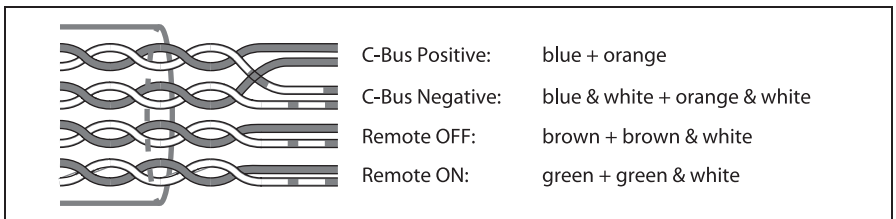

Figure 3 - C-Bus cable conductor assignments

## 6.0 C-Bus Network Connection

C-Bus Connection	Colour	509xNL Connection
Remote ON	green & white	N/A
Remote ON	green	N/A
C-Bus Negative (-)	orange & white	yes
C-Bus Positive (+)	blue	yes
C-Bus Negative (-)	blue & white	yes
C-Bus Positive (+)	orange	yes
Remote OFF	brown & white	N/A
Remote OFF	brown	N/A

Table 1 - C-Bus cable connections

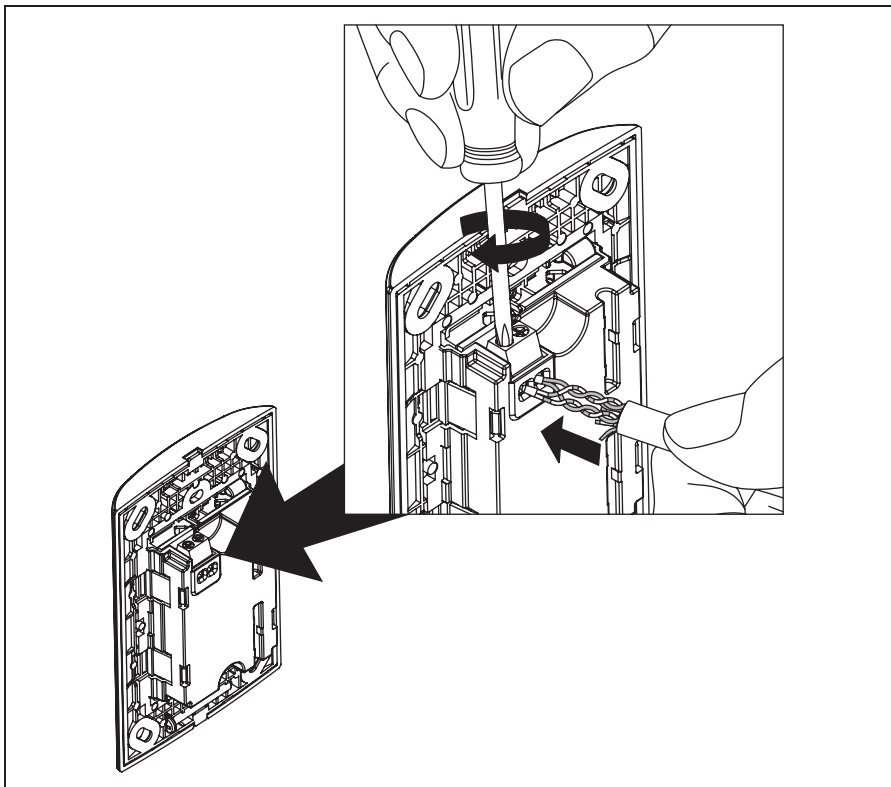

Table 2 - Connecting a C-Bus Large Rocker Switch to the C-Bus network

## 7.0 C-Bus Power Requirements

The 509xNL C-Bus Large Rocker Switch draws 18 mA from the C-Bus network. Adequate C-Bus Power Supply Units must be installed to support the connected devices.

The Network window of a C-Bus Toolkit project provides a summary of a C-Bus network according to the units added to the Database. This can be helpful in determining the power supply requirements of a particular network.

## 8.0 Megger Testing

Important points when megger testing an electrical installation:

- Only megger test when mains cabling is disconnected from C-Bus output units.
- Do not megger test the C-Bus cable.

## 9.0 Programming Requirements

C-Bus Large Rocker Switches are learn enabled devices. This means you can create relationships between input and output units without a computer (using learn mode).

Learn mode allows you to link multiple units into a common network. You can assign a load such as a light on a dimmer unit, with a controller such as the C-Bus Large Rocker Switch, by touching the two units one after the other. Refer to the "Quick start guide to programming: C-Bus2 Learn Units" booklet for more information.

In a sophisticated installation, some of the basic settings created by learn mode may need to be overridden to create a particular effect. The latest C-Bus Toolkit software may be downloaded from the Clipsal Integrated Systems website ([www.clipsal.com/cis](http://www.clipsal.com/cis)).

## 10.0 Electrical Specifications

Parameter	Description
C-Bus supply voltage	15 to 36 V DC, 18 mA for normal operation. Does not provide current to the C-Bus network.
C-Bus AC input impedance	100 k $\Omega$ @ 1 kHz
Electrical isolation	3.75 kV RMS from C-Bus to mains (provided externally to 509xNL Series unit)
Max. number of units per network	100
Control functions	Load switching, dimming, timers, scene control
Status indicators	User configurable green and red
Warm-up time	5 seconds
C-Bus connection	One terminal block to accommodate 0.2 to 1.3 mm <sup>2</sup> (24 to 16 AWG)
Operating temperature range	0 to 45 °C
Operating humidity range	10 to 95% RH

## 11.0 Mechanical Specifications

Parameter	Description
Dimensions (W × H × D)	121 × 82 × 29 mm (4.76 × 3.23 × 1.14 inches)
Protrusion from wall	13 mm (0.51 inches)
Mounting centres	84 mm
Weight	5091NL,WE - 87 g
Weight	5092NL,WE - 89 g
Weight	5093NL,WE - 91 g

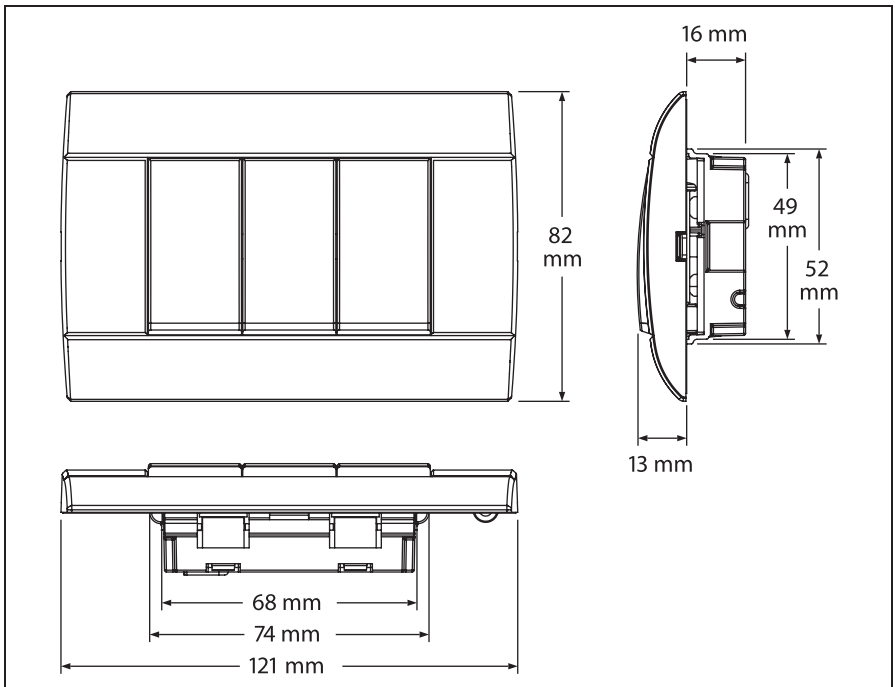

# 12.0 Standards Complied

## DECLARATIONS OF CONFORMITY

*Australian/New Zealand EMC & Electrical Safety Frameworks and Standards*  
509xNL C-Bus Large Rocker Switches comply with the following:



Regulation	Standard	Title
EMC (C-Tick)	AS/NZS1044, CISPR 14-1	RFI Emissions

*European Directives and Standards*  
509xNL C-Bus Large Rocker Switches comply with the following:



European Council Directive	Standard	Title
EMC Directive 89/336/EEC	EN55014-1	Electrical Motor-operated and Thermal Appliances
	EN60669-2-1	Switches for Household and Similar Fixed Electrical Installations Part 2-1
	EN61000-3-2	Limits for Harmonic Current Emissions
	EN61000-3-3	Limitation of Voltage Changes, Fluctuations and Flicker
	EN61000-4-2	Immunity to ESD
	EN61000-4-3	Immunity to RF EM Fields
	EN61000-4-4	Immunity to EFT
	EN61000-4-5	Immunity to Surge Voltages
	EN61000-4-6	Continuous RF Immunity

*Other International Directives and Standards*  
509xNL C-Bus Large Rocker Switches comply with the following:

Regulation	IEC Standard	Title
EMC	60669-2-1	Switches for Household and Similar Fixed Electrical Installations Part 2-1
	61000-3-2	Limits for Harmonic Current Emissions
	61000-3-3	Voltage Fluctuations and Flicker Standard
	61000-4-2	Immunity to ESD
	61000-4-3	Immunity to RF EM Fields
	61000-4-4	Immunity to EFT
	61000-4-5	Immunity to Surge Voltages

## 13.0 Warranty

509xNL C-Bus Large Rocker Switches carry a two year warranty against manufacturing defects.

### Warranty Statement

- 1) The benefits conferred herein are in addition to, and in no way shall be deemed to derogate; either expressly or by implication, any or all other rights and remedies in respect to Clipsal Integrated Systems Product, which the consumer has under the Commonwealth Trade Practices Act or any other similar State or Territory Laws.
- 2) The warrantor is Clipsal Australia Pty Ltd of 12 Park Terrace, Bowden, South Australia, 5007. Telephone (08) 8345 9500. With registered offices in all Australian States.
- 3) This Clipsal Integrated Systems Product is guaranteed against faulty workmanship and materials for a period of two (2) years from the date of installation.
- 4) Clipsal Australia Pty Ltd reserves the right, at its discretion, to either repair free of parts and labour charges, replace or offer refund in respect to any article found to be faulty due to materials, parts or workmanship.
- 5) This warranty is expressly subject to the Clipsal Integrated Systems Product being installed, wired, tested, operated and used in accordance with the manufacturer's instructions.
- 6) All costs of a claim shall be met by Clipsal Australia Pty Ltd, however should the product that is the subject of the claim be found to be in good working order, all such costs shall be met by the claimant.
- 7) When making a claim, the consumer shall forward the Clipsal Integrated Systems Product to the nearest office of Clipsal Australia Pty Ltd with adequate particulars of the defect within 28 days of the fault occurring. The product should be returned securely packed, complete with details of the date and place of purchase, description of load, and circumstances of malfunction.

For all warranty enquiries, contact your local Clipsal sales representative. The address and contact number of your nearest Clipsal Australia office can be found at <http://www.clipsal.com/locations> or by telephoning Technical Support (refer to the back page).

## Technical Support and Troubleshooting

For further assistance in using this product, consult your nearest Clipsal Integrated Systems (CIS) Sales Representative or Technical Support Officer.

Technical Support Contact Numbers	
Australia	1300 722 247 (CIS Technical Support Hotline)
New Zealand	0800 888 219 (CIS Technical Support Hotline)
Northern Asia	852 2484 4157 (Clipsal Hong Kong)
South Africa	(011) 314 5200 (C-Bus Technical Support)
Southern Asia	603 7665 3555 Ext. 236 or 242 (CIS Malaysia)
United Kingdom	0870 608 8 608 (Schneider Electric Support)

Technical Support email: [techsupport.cis@clipsal.com.au](mailto:techsupport.cis@clipsal.com.au)

Sales support email: [sales.cis@clipsal.com.au](mailto:sales.cis@clipsal.com.au)

Worldwide contacts are provided at <http://www.clipsal.com/locations/>

Information and resources are provided at <http://www.clipsal.com/cis/>

---

### Clipsal Australia Pty Ltd

A member of Schneider Electric

Contact us: [clipsal.com/feedback](http://clipsal.com/feedback)

National Customer Care Enquiries:

**Tel 1300 2025 25**

**Fax 1300 2025 56**

**clipsal.com**

Clipsal Australia Pty Ltd reserves the right to change specifications, modify designs and discontinue items without incurring obligation and whilst every effort is made to ensure that descriptions, specifications and other information in this catalogue are correct, no warranty is given in respect thereof and the company shall not be liable for any error therein.

© Clipsal Australia Pty Ltd. The identified trademarks and copyrights are the property of Clipsal Australia Pty Ltd unless otherwise noted.