

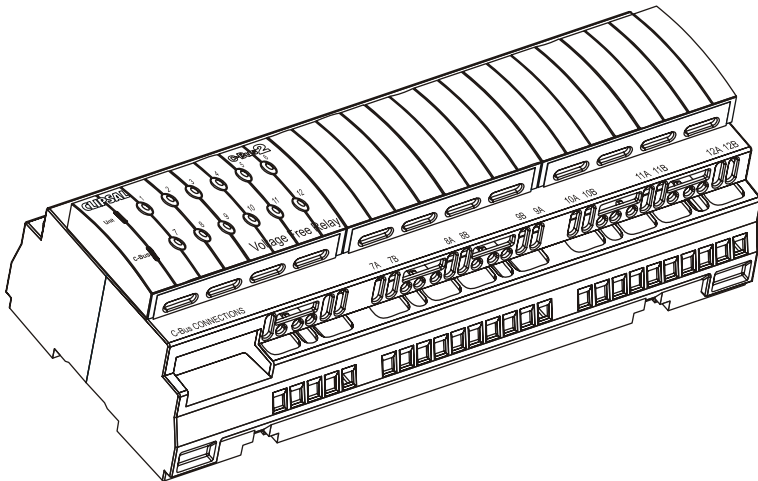

C-Bus 8 and 12 Channel Voltage Free Relay

Installation Instructions

55xxRVF Series



© Copyright Clipsal Integrated Systems Pty Ltd 2005. All rights reserved. This material is copyright under Australian and international laws. Except as permitted under the relevant law, no part of this work may be reproduced by any process without prior written permission of and acknowledgement to Clipsal Integrated Systems Pty Ltd.

Clipsal and C-Bus are registered trademarks of Clipsal Australia Pty Ltd.
Neo is a trademark of Clipsal Integrated Systems Pty Ltd

The information in this manual is provided in good faith. Whilst Clipsal Integrated Systems (CIS) has endeavoured to ensure the relevance and accuracy of the information, it assumes no responsibility for any loss incurred as a result of its use. CIS does not warrant that the information is fit for any particular purpose, nor does it endorse its use in applications which are critical to the health or life of any human being. CIS reserves the right to update the information at any time without notice.

V2.1 June 2005

Contents

1.0	Product Range	5
2.0	Important Notes	5
3.0	Description	5
4.0	Capabilities	6
5.0	Compatible Loads	8
6.0	Wiring Instructions	8
7.0	C-Bus Network Connection	10
8.0	Features	12
	8.1 Local Override	12
	8.2 Remote Override	12
9.0	Priority of Operating Modes	13
10.0	Status Indicators	14
	9.1 C-Bus Indicator	14
	9.2 Unit Indicator	15
11.0	C-Bus System Clock	15
12.0	C-Bus Network Burden	16
13.0	Power-Up Load Status	16
14.0	C-Bus Power Requirements	16
15.0	Power Surges	17
16.0	Megger Testing	17
17.0	Programming	17
18.0	Electrical Specifications	18
19.0	Mechanical Specifications	19
20.0	Standards Complied	20

1.0 Product Range

Catalogue No.	Channels	Supply Voltage (50 or 60 Hz)	On-Board Power Supply
L5508RVF	8	220 to 240 V	✓
L5508RVFP	8	220 to 240 V	✗
LE5508TRVF	8	110 to 120 V	✓
LE5508TRVFP	8	110 to 120 V	✗
L5512RVF	12	220 to 240 V	✓
L5512RVFP	12	220 to 240 V	✗
LE5512TRVF	12	110 to 120 V	✓
LE5512TRVFP	12	110 to 120 V	✗

2.0 Important Notes

- Disable the network burden on all 5100PC Interface units before installing C-Bus DIN range products which include a power supply. (The 5100PC is a superseded non DIN rail unit). If a burden is required, use the built-in burden on the DIN rail unit only.
- The use of any software not provided by Clipsal Integrated Systems (CIS) in conjunction with the installation of these products may void any warranties applicable to the hardware.

3.0 Description

C-Bus 55xxRVF Series 8 and 12 Channel Voltage Free Relays are C-Bus output devices designed to be used in a switchboard application. Either 8 or 12 independent voltage free relay contacts are provided for general switching applications. For ease of installation they are DIN rail mounted, measuring 12 modules wide (1 module = 17.5 mm). C-Bus connection is conveniently achieved through the use of RJ45 connectors, allowing similar units to be quickly looped together.

4.0 Capabilities

C-Bus 55xxRVF Series Voltage Free Relays have an internal C-Bus power supply capable of supporting a number of other C-Bus units (200 mA capacity). All units with a suffix of “P” do not have a C-Bus power supply, but consume no current from the C-Bus network during normal operation.

These units also generate a C-Bus system clock signal, providing all the support necessary for a simple C-Bus network. Local toggle buttons are provided on each unit to allow individual channels to be switched locally (overriding the current C-Bus state). Remote On and Off facilities are available, permitting all channels to be turned on or off without C-Bus network communication. These units isolate mains power from the extra low voltage C-Bus network.

5.0 Compatible Loads

Table 1 shows the loads which are compatible with C-Bus 55xxRVF Series Voltage Free Relays. Load types are described on the following page.





Load Symbol	Compatible Loads	Load Rating Per Channel
	Incandescent lighting Halogen 110/240 V lamps	10 A
	Fluorescent lighting	
	Resistive load	
	Low voltage or neon lighting with iron-core transformers	
	Low voltage or neon lighting with electronic transformers	
	* Exhaust fans (shaded pole induction motors) * Ceiling fans (split-phase induction motors)	2 A

Table 1 – Loads compatible with the 55xxRVF series

* The installer must ensure that an appropriate manually operated mechanical isolating switch and circuit breaker is installed with the motor, in order to comply with local wiring rules applicable to the region.

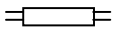
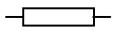
Resistive

This generally refers to heating elements. The resistance characteristic of this load type is essentially constant. The load switch/relay contacts are not subjected to higher current at switch-on.

Incandescent

This includes filament lamps of any kind. The resistance characteristic of this load type is non-linear, resulting in significantly greater current magnitude when the lamp is switched on. This places greater stresses on switch/relay contacts.

Fluorescent

Traditional iron-core ballasted fluorescent lamps are typically fitted with an across-the-line power-factor-correction (PFC) capacitor, to achieve a near unity power factor. The load switch/relay contacts may be subjected to extremely high, short duration, current magnitudes each time the lamp is switched on.

The PFC capacitor effectively suppresses potential inductive ballast induced switch/relay contact arcing effects at lamp switch off.

Inductive

This load category includes:

- iron-core transformer based low-voltage lighting (slightly inductive, high power factor load)
- iron-core transformer based neon lighting (highly inductive, low power factor load)
- non-PFC fluorescent lighting (highly inductive, low power factor load)
- exhaust fan motors – shaded pole induction type (highly inductive, low power factor load)
- ceiling fan motors – split phase induction type (highly inductive, low power factor load).

The inductive nature of these loads may result in switch/relay contact arcing effects at load switch off, being somewhat dependent on how inductive the load is.

The iron-core transformer based low-voltage lighting load type will also impose a larger current magnitude when the lamp is switched on from the cold state, placing greater stresses on switch/relay contacts.

Iron-core transformer loads generally exhibit high inrush current magnitudes, for a number of mains cycles at switch on, again placing greater stresses on switch/relay contacts.

Motor

This inductive load category generally refers to motors used for industrial applications (typically any application excluding regular exhaust fans or ceiling fans). A characteristic of this load type is high starting current which places significantly greater stresses on switch/relay contacts. The inductive nature of these loads may also result in switch/relay contact arcing effects at load switch off.

6.0 Wiring Instructions

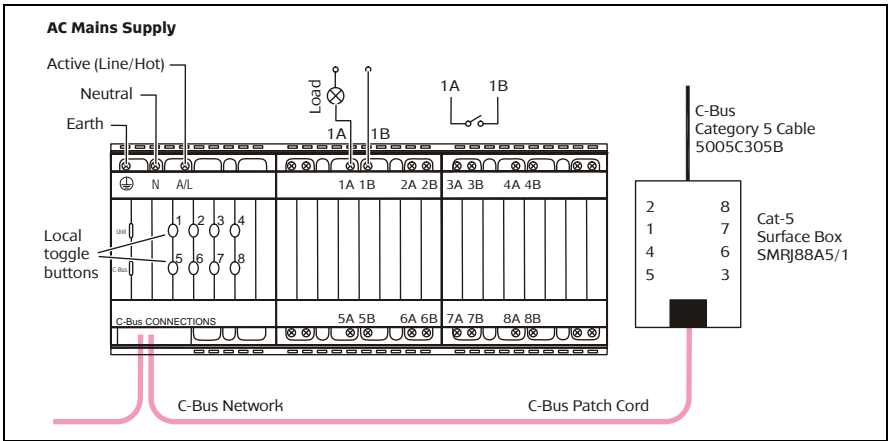

Figure 1 – 5508RVF series wiring

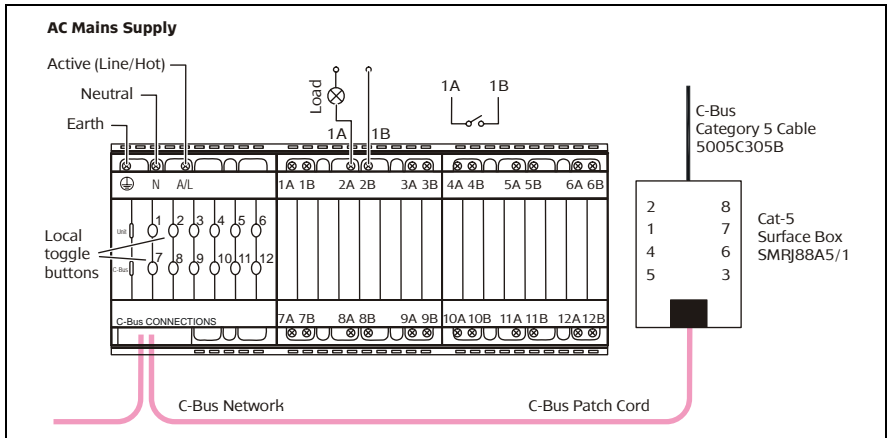

Figure 2 – 5512RVF series wiring

Wiring diagrams for the C-Bus Voltage Free Relays are provided in Figures 1 and 2. Consider the following points when installing these units:

- Units are capable of handling up to 8 or 12 channels of 10 A switched active loads. Ensure you consider the total current consumption when selecting power feed cables, and allow for multiple feed cables. Each feed cable must have an appropriate MCB to protect that load circuit.
- A maximum of 10 C-Bus DIN Rail units (with 200 mA power supplies) can be connected to a single C-Bus network. A maximum of 100 “P” suffix units may be connected.
- Fix mains cables in the distribution board using cable ties or trunking as required by local wiring rules. Take care not to allow copper strands to enter the DIN unit’s apertures.
- Apply a maximum torque of 1.4 Nm to the mains rated screw terminals.
- Rubber bungs are supplied (3 off) for unused RJ45 connectors, to stop foreign bodies from entering the unit. Always install these bungs when the unit is mounted inside a mains rated enclosure.
- Use copper wire only.

7.0 C-Bus Network Connection

Connection to the C-Bus network is made via one of the RJ45 sockets. Use Cat-5 Unshielded Twisted Pair (UTP) C-Bus cable, and an appropriately wired RJ45 plug. Pinouts and cable conductor assignments are provided in Figure 3 and Table 2. The RJ45 sockets are internally connected. The Clipsal catalogue number for the C-Bus Cat-5 UTP cable is 5005C305B.

It is recommended that the Remote Override (On/Off) connections be maintained for correct operation of these services across the C-Bus network, even if they are not intended to be used. Remote Override services may be disabled in software if necessary.

A Clipsal RJ5CB300PL Cat-5 UTP patch cord is included with the unit for easy interconnection. No more than 10 × 55xxRVF Series products should be connected to one physical C-Bus network. This may be extended to 100 for “P” suffix units.

Rubber bungs are supplied (×3) for unused RJ45 connectors, to stop foreign bodies from entering the unit. Always ensure these bungs are installed when the unit is mounted inside a mains rated enclosure.

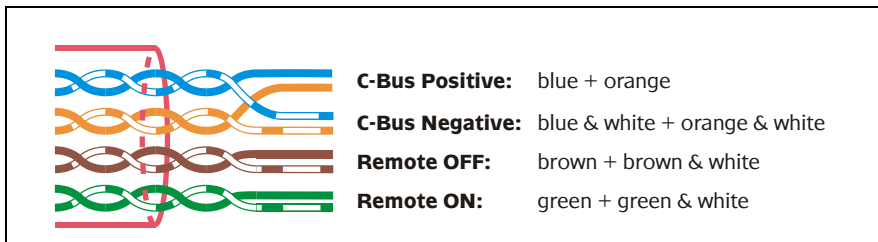

Figure 3 – C-Bus cable conductor assignments

Pin	C-Bus Connection	Colour
1	Remote ON	green & white
2	Remote ON	green
3	C-Bus Negative (-)	orange & white
4	C-Bus Positive (+)	blue
5	C-Bus Negative (-)	blue & white
6	C-Bus Positive (+)	orange
7	Remote OFF	brown & white
8	Remote OFF	brown

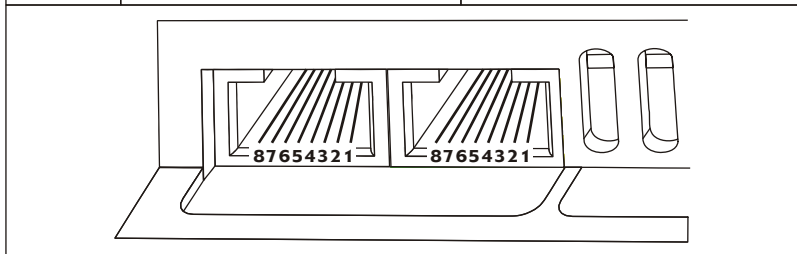

Table 2 – RJ45 sockets and C-Bus pinouts

8.0 Features

8.1 Local Override

The local toggle buttons located on the front of the unit toggle each channel on and off, providing local override capability. Each button illuminates when its respective channel is in the on state. Local toggle buttons perform different functions depending on how they are pressed. This is summarised in Table 3.

Operation	Function
Quick-press	A single quick-press toggles the state of a channel
Double quick-press	Two quick-presses in quick succession return the channel to the C-Bus network level
Long press	Pressing any of the local toggle buttons for 1 second or more returns all channels to the C-Bus network level

Table 3 – Local toggle button functions

Note that double quick-press and long press operations only apply when the unit/channel is in local override mode. C-Bus commands received by the unit will (by default) override local toggle changes. In this case, only the channel associated with the received commands will revert to the current C-Bus network state. This option may be disabled in software. Please refer to Section 9.0, Priority of Operating Modes.

8.2 Remote Override

Remote control of all channels on a unit can be achieved via the extra pairs of conductors on the C-Bus connector. Figure 4 illustrates how switches may be connected to these conductors. Green + green & white conductors are used for the Remote On function. Brown + brown & white are used for Remote Off. The Remote Override is triggered by connecting the relevant conductors to C-Bus negative. A Clipsal 30/1/2LM mechanism makes an ideal remote input switch.

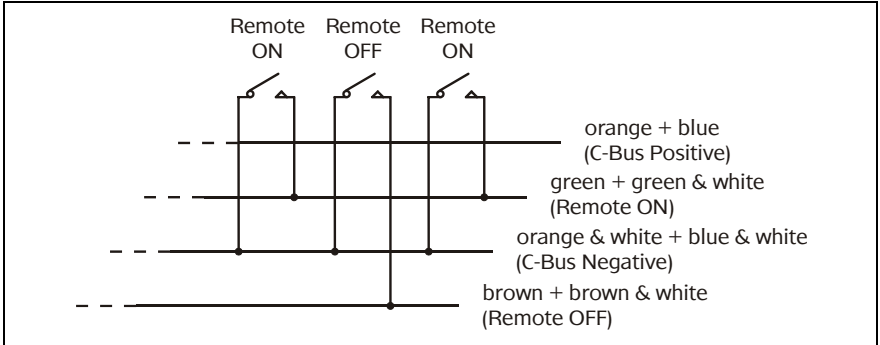

Figure 4 – Remote Override connections



NOTE C-Bus is a balanced network and therefore at any point where C-Bus negative (-) is taken, C-Bus positive (+) must also be present. For this reason both conductor pairs must be looped through all remote input switches on the network.

9.0 Priority of Operating Modes

The output status of C-Bus 55xxRVF Series Voltage Free Relays can be changed by:

- pressing a C-Bus button
- activating any of the local toggle buttons (local override)
- using the Remote Override facility.

Table 4 shows the priority ranking of these control inputs,

Mode	Priority	Function
Remote Off	1 (highest)	All channels off
Remote On	2	All channels on
Local override	3*	Toggles the channel
C-Bus input unit (Neo, PIR, etc.)	4* (lowest)	Controls the channel

Table 4 – Control input priority ranking

*Using local toggle buttons overrides the normal C-Bus commands such as those issued by input units. By default, once a channel is in local override mode, further relevant C-Bus commands issued by input and control units will override the local override state. This feature can be disabled in software so that all relevant C-Bus commands are ignored by the unit when it is in local override mode.

Further information about programming C-Bus units is provided at the Clipsal Integrated Systems web site (<http://www.clipsal.com/cis>).

10.0 Status Indicators

10.1 C-Bus Indicator

The “C-Bus” indicator shows the status of the C-Bus network at the unit. If sufficient network voltage and a valid C-Bus clock signal are present, the indicator illuminates (as a continuous green light). If a network is connected which has a higher current load than the power supplies support, the indicator flashes to show a marginal network voltage. If no C-Bus clock is present, or if the unit is powered by C-Bus only (for stand-alone programming), the indicator remains off.

Indicator Status	Meaning
On	Power is on and functional
Flashing	There is insufficient power to support the C-Bus network
Off	No C-Bus clock signal is present and/or mains power is not connected

Table 5 – The “C-Bus” indicator

Further debugging of possible network problems can be achieved using the Clipsal C-Bus Network Analyser tool (5100NA).

10.2 Unit Indicator

The “Unit” indicator shows the status of the individual unit. When mains power is supplied, the indicator illuminates (as a continuous green light). If a local toggle button has been used to perform a local override, or if a Remote Override is active, the indicator flashes with a 90% duty cycle. The Unit indicator does not function when the unit is powered by C-Bus only (for stand-alone programming).

Indicator Status	Meaning
On	Normal operation
Flashing	Unit is in override mode
Off	No mains power is connected

Table 6 – The “Unit” indicator

11.0 C-Bus System Clock

C-Bus 55xxRVF Series Voltage Free Relays incorporate a software selectable C-Bus system clock. The system clock is used to synchronise data communication over a C-Bus network. At least one active C-Bus system clock is required on each C-Bus network for successful communication. No more than three units on any C-Bus network should have clock circuitry enabled, so this option is normally disabled using the C-Bus Toolkit software.

If a system clock is required, it can be enabled from the unit’s “Global” tab in the C-Bus Toolkit software.

12.0 C-Bus Network Burden

C-Bus 55xxRVF Series Voltage Free Relays incorporate a software selectable network burden. The network burden can be enabled from the unit's "Global" tab in the C-Bus Toolkit software, but only if the C-Bus system clock is enabled, and the Unit Address is set to 1.

One network burden is normally required to ensure correct operation of each C-Bus network. The Network window of a C-Bus Toolkit project provides a summary of a C-Bus network according to the units added to the Database. This can be helpful in determining whether or not a burden is required on a particular network.



Disable the network burden on all 5100PC Interface units before installing C-Bus DIN range products which include a power supply. (The 5100PC is a superseded non-DIN rail unit). If a burden is required, use the built-in burden on the DIN rail unit only.

13.0 Power-Up Load Status

C-Bus output units have on-board non-volatile memory, which is used to store the operating state of the unit in case of power loss. The 55xxRVF Series products incorporate latching relays and will retain their current output status if C-Bus power is lost. On restoration of power the units initiate a short power-up diagnostic routine, which lasts for approximately 5 seconds. Channels are then restored according to their previous states, and according to the unit's recovery and restrike delay settings.

14.0 C-Bus Power Requirements

C-Bus 55xxRVF Series Voltage Free Relays are available in several configurations. All variants draw 18 mA from the C-Bus network when not connected to the mains supply. Units draw no current from the C-Bus network when mains power is connected.

In addition, units with no "P" suffix on their catalogue number (such as the L5508RVF and L5512RVF) supply up to 200 mA to the network when connected to the mains. "P" suffix variants (such as the L5508RVFP or L5512RVFP) do not include the 200 mA power supply.

Adequate C-Bus Power Supply Units must be installed to support connected devices. If in doubt, consult the C-Bus Calculator (Network Design Verification Software Utility) before proceeding with the hardware installation.

15.0 Power Surges

Each unit incorporates transient protection circuitry. Additional external power surge protection devices should be used to enhance system immunity to power surges. It is strongly recommended that overvoltage equipment such as the Clipsal 970 be installed at the switchboard.

16.0 Megger Testing

Megger testing must never be performed on the C-Bus data cabling or terminals as it could degrade the performance of the network.

Megger testing of a mains electrical installation that has C-Bus units connected will not damage the units. Since C-Bus units contain electronic components, this should be taken into account when interpreting megger readings.

17.0 Programming

As with other C-Bus units, a 55xxRVF Series Voltage Free Relay must be programmed before it will function as part of a C-Bus network. This can be accomplished using Learn Mode. However, using the C-Bus Toolkit software provides a greater level of flexibility and customisation.

Units do not need a mains connection in order to be programmed via the C-Bus Toolkit. They can be connected to any operational C-Bus network that is capable of supporting one or more extra C-Bus units (18 mA current required). Units can then be configured using the Toolkit software. Indicators and relays will only function when a mains connection is established.

The C-Bus Toolkit software can be downloaded from the Clipsal Integrated Systems web site (www.clipsal.com/cis). Further information about programming C-Bus units is provided at this site.

18.0 Electrical Specifications

Parameter	Description			
	L5508RVF L5512RVF	LE5508TRVF LE5512TRVF	L5508RVFP L5512RVFP	LE5508TRVFP LE5512TRVFP
Nominal supply voltage	220 to 240 V AC	110 to 120 V AC	220 to 240 V AC	110 to 120 V AC
Frequency range	47 to 53 Hz and 57 to 63 Hz			
C-Bus supply voltage	15 to 36 V DC @ 18 mA required for programming when mains is not connected. Supplies 200 mA to the C-Bus network when mains is connected.		15 to 36 V DC @ 18 mA required for programming when mains is not connected. 15 to 36 V DC @ 0 mA required for programming when mains is connected. Does not supply current to the C-Bus network.	
AC input impedance	50 kΩ @1 kHz		100 kΩ @1 kHz	
Electrical isolation	3.75 kV RMS from C-Bus to mains			
Max. units per network	10		100	
Load rating	Resistive: 10 A, inductive: 10 A, fluorescent: 10 A, motor: 2 A			
Switch operations	Greater than 60, 000 operations at rated load (see above for load types)			
Contact type	Voltage free, magnetically latched			
Quiescent power	10 Watts			
Warm up time	5 seconds			
Restart delay	0 seconds to 42 minutes and 30 seconds			
Network clock	Software selectable			
Network burden	Software selectable			
Operating temperature	0 to 45 °C (32 to 113 °F)			
Operating humidity	10 to 95% RH			

19.0 Mechanical Specifications

Parameter	Description
Dimensions (W×H×D)	216 × 92 × 63 mm (8.5 × 3.62 × 2.48 inches)
Weight	L5508RVF/LE5508TRFV: 525 g (19 oz) L5508RVFP/LE5508TRVFP: 725 g (26 oz) L5512RVF/LE5512TRVF: 600 g (21 oz) L5512RVFP/LE5512TRVFP: 800 g (28 oz)
Mains terminals	Accommodates 2 × 1.5 mm ² or 1 × 2.5 mm ² (2 × 16 AWG or 1 × 13 AWG)
C-Bus connections	RJ45 sockets

Both 8 and 12 channel models have the same dimensions (12 channel is shown). No user serviceable parts inside.

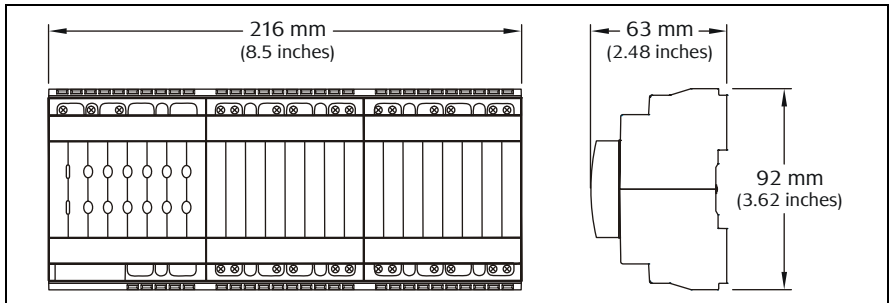

20.0 Standards Complied

DECLARATIONS OF CONFORMITY

Australian/New Zealand EMC & Electrical Safety Frameworks and Standards

Model L55xxRVF Series products comply with the following:



Regulation	Standard	Title
EMC (C-Tick)	AS1044, AS/NZS 61000-3-2	RFI Emissions Standard
Electrical Safety	AS/NZS 3100 AS/NZS 61558-1	General Requirements for Electrical Equipment Safety of Power Supplies and Transformers

European Directives and Standards

Model L55xxRVF Series products comply with the following:



European Council Directive	Standard	Title
EMC Directive 89/336/EEC	EN 55014	RFI Emissions Standard
	EN 60669-2-1 Clause 26.1	Immunity to ESD, RFI, EFT, Surge Voltages, Voltage Dips and Interruptions
	EN 60669-2-1 Clause 26.2	RF and Low Frequency Emissions
Low Voltage Directive 73/23/EEC	EN 60669-2-1	Switches for Household Fixed Electrical Installations Part 2-1
	EN 61558-1	Safety of Power Supplies and Transformers

US and Canadian Product Safety Standards and US FCC Regulations

Model L55xxRVF Series products comply with the following:



Standard/Regulation	Title
CSA C22.2 No. 14 UL508	Industrial Control Equipment Industrial Control Equipment
Tested to FCC Standards for Home or Office Use	FCC Part 15 ANSI C63.4



Supplemental Information

This device complies with part 15 of the FCC Rules. Operation is subject to the following two conditions: (1) this device may not cause harmful interference, and (2) this device must accept any interference received, including interference that may cause undesirable operation.

Class B Product

NOTE:

This equipment has been tested and found to comply with the limits for a Class B digital device, pursuant to Part 15 of the FCC Rules. These limits are designed to provide reasonable protection against harmful interference in a residential installation. This equipment generates, uses and can radiate radio frequency energy and, if not installed and used in accordance with the instructions, may cause harmful interference to radio communications. However, there is no guarantee that interference will not occur in a particular installation. If this equipment does cause harmful interference to radio or television reception, which can be determined by turning the equipment off and on, the user is encouraged to try to correct the interference by one or more of the following measures:

- reorient or relocate the receiving antenna
- increase the separation between the equipment and receiver
- connect the equipment into an outlet on a circuit different from that to which the receiver is connected
- consult the dealer or an experienced radio/TV technician for help.

Warning: Any changes or modifications not expressly approved by Clipsal Integrated Systems could void the user's authority to operate this equipment.

Other International Directives and Standards

Model 5504DxA and 5508DxA Series products comply with the following:

Regulation	IEC Standard	Title
EMC	60669-2-1 Clause 26.1	Immunity to ESD, RFI, EFT, Surge Voltages, Voltage Dips and Interruptions
	60669-2-1 Clause 26.2	RF and Low Frequency Emissions
Electrical Safety	61558-1	Safety of Power Supplies and Transformers
	60669-2-1	Switches for Household Fixed Electrical Installations Part 2-1



Technical Support and Troubleshooting

For further assistance in using this product, consult your nearest Clipsal Integrated Systems Sales Representative or Technical Support Officer.

Technical Support Hotline: 1300 722 247 (Australia)
0800 888 219 (New Zealand)

Technical Support Email: techsupport.cis@clipsal.com.au

Sales Support Email: sales.cis@clipsal.com.au

A list of worldwide contacts, additional product information and technical resources is provided at <http://www.clipsal.com/cis/>

Product of Clipsal Integrated Systems Pty Ltd

ABN 15 089 444 931

Head Office

12 Park Terrace, Bowden, SA 5007, Australia

Telephone: (+61) 8 8440 0500

Facsimile: (+61) 8 8346 0845

Email: cis@clipsal.com.au

Web: <http://www.clipsal.com/cis/>

10364533